

## Contents of Schedule 6

<b>Schedule 6</b>	<b>Planning scheme policies</b>	<b>6:5</b>
<b>SC6.1</b>	<b>Planning scheme policy index</b>	<b>6:5</b>
<b>SC6.1.1</b>	<b>Scope of the Planning Scheme Policies</b>	<b>6:5</b>
<b>SC6.2</b>	<b>Environmental features planning scheme policy</b>	<b>6:8</b>
<b>SC6.2.1</b>	<b>Introduction</b>	<b>6:8</b>
SC6.2.1.1	Relationship to the Planning Scheme	6:8
SC6.2.1.2	Purpose	6:8
SC6.2.1.3	Environmental features overlay mapping	6:8
<b>SC6.2.2</b>	<b>Requirements of environmental features documentation</b>	<b>6:10</b>
<b>SC6.2.3</b>	<b>Acid sulfate soils assessment report</b>	<b>6:12</b>
SC6.2.3.1	Purpose of an Acid sulfate soils assessment report	6:12
SC6.2.3.2	Preparation of an Acid sulfate soils assessment report	6:12
<b>SC6.2.4</b>	<b>Acid sulfate soils management plan</b>	<b>6:13</b>
SC6.2.4.1	Purpose of an Acid sulfate soils management plan	6:13
SC6.2.4.2	Preparation of an Acid sulfate soils management plan	6:13
<b>SC6.2.5</b>	<b>Ecological assessment report</b>	<b>6:15</b>
SC6.2.5.1	Purpose of an Ecological assessment report	6:15
SC6.2.5.2	Undertaking an Ecological assessment report	6:15
SC6.2.5.3	Preparation of a Tree survey plan	6:17
SC6.2.5.4	Preparation of an Ecological assessment report	6:17
<b>SC6.2.6</b>	<b>Renewable Energy Facility Visual Impact Assessment</b>	<b>6:20</b>
SC6.2.6.1	Purpose of a Renewable Energy visual impact assessment	6:20
SC6.2.6.2	Undertaking a Renewable energy facility visual impact assessment	6:20
<b>SC6.2.7</b>	<b>Stormwater management plan</b>	<b>6:23</b>
SC6.2.7.1	Purpose	6:23
SC6.2.7.2	Requirements of stormwater quality documentation	6:23
SC6.2.7.3	Preparation of a Stormwater Quality Management Plan (SQMP)	6:23
SC6.2.7.4	Preparation of a Stormwater Quality Management Plan Additional Guidelines	6:26
<b>SC6.2.8</b>	<b>Vegetation management plan</b>	<b>6:27</b>
SC6.2.8.1	Purpose of a Vegetation management plan	6:27
SC6.2.8.2	Preparation of a Vegetation management plan	6:27
<b>SC6.3</b>	<b>Heritage planning scheme policy</b>	<b>6:30</b>
<b>SC6.3.1</b>	<b>Introduction</b>	<b>6:30</b>

SC6.3.1.1	Relationship to the Planning Scheme .....	6:30
SC6.3.1.2	Purpose .....	6:30
SC6.3.1.3	Heritage overlay mapping .....	6:30
<b>SC6.3.2</b>	<b>Requirements of heritage documentation .....</b>	<b>6:31</b>
<b>SC6.3.3</b>	<b>Heritage impact assessment report .....</b>	<b>6:33</b>
SC6.3.3.1	Purpose of a Heritage impact assessment report.....	6:33
SC6.3.3.2	Preparation of a Heritage impact assessment report	6:33
<b>SC6.3.4</b>	<b>Heritage management plan .....</b>	<b>6:34</b>
SC6.3.4.1	Purpose of a Heritage management plan .....	6:34
SC6.3.4.2	Preparation of a Heritage management plan .....	6:34
<b>SC6.3.5</b>	<b>Archaeological management plan .....</b>	<b>6:35</b>
SC6.3.5.1	Purpose of an Archaeological management plan .....	6:35
SC6.3.5.2	Preparation of an Archaeological management plan	6:35
<b>SC6.4</b>	<b>Landscaping planning scheme policy .....</b>	<b>6:36</b>
<b>SC6.4.1</b>	<b>Introduction .....</b>	<b>6:36</b>
SC6.4.1.3	Relationship to the Planning Scheme .....	6:36
SC6.4.1.4	Purpose .....	6:36
<b>SC6.4.2</b>	<b>Requirements of landscaping documentation .....</b>	<b>6:37</b>
<b>SC6.4.3</b>	<b>Landscaping plan .....</b>	<b>6:38</b>
SC6.4.3.1	Purpose of a Landscaping plan .....	6:38
SC6.4.3.2	Preparation of a Landscaping plan .....	6:38
<b>SC6.4.4</b>	<b>Landscaped separation buffer plan .....</b>	<b>6:40</b>
SC6.4.4.1	Purpose of a Landscaped separation buffer plan .....	6:40
SC6.4.4.2	Preparation of a Landscaped separation buffer plan	6:40
<b>SC6.4.5</b>	<b>Planting species list .....</b>	<b>6:44</b>
SC6.4.5.1	Purpose of the planting species list .....	6:44
SC6.4.5.2	Planting species list .....	6:44
<b>SC6.5</b>	<b>Natural hazards planning scheme policy .....</b>	<b>6:53</b>
<b>SC6.5.1</b>	<b>Introduction .....</b>	<b>6:53</b>
SC6.5.1.1	Relationship to the Planning Scheme .....	6:53
SC6.5.1.2	Purpose .....	6:53
SC6.5.1.3	Hazard overlay mapping .....	6:53
<b>SC6.5.2</b>	<b>Requirements of natural hazard documentation .....</b>	<b>6:54</b>
<b>SC6.5.3</b>	<b>Coastal hazard assessment report .....</b>	<b>6:56</b>
SC6.5.3.1	Purpose of a Coastal hazard assessment report.....	6:56
SC6.5.3.2	Desired outcomes for a Coastal hazard assessment report .....	6:56
SC6.5.3.3	Undertaking a Coastal hazard assessment report....	6:56
SC6.5.3.4	Preparation of a Coastal hazard assessment report	6:57
<b>SC6.5.4</b>	<b>Flood hazard assessment report .....</b>	<b>6:58</b>

SC6.5.4.1	Purpose of a Flood hazard assessment report .....	6:58
SC6.5.4.2	Preparing a Flood hazard assessment report.....	6:58
<b>SC6.5.5</b>	<b>Landslide hazard (geotechnical) assessment report .....</b>	<b>6:60</b>
SC6.5.5.1	Purpose of a Landslide hazard (geotechnical) assessment report.....	6:60
SC6.5.5.2	Risk assessment criteria .....	6:60
SC6.5.5.3	Preparing a Landslide hazard (geotechnical) assessment report.....	6:60
<b>SC6.6</b>	<b>Third party advice or comment planning scheme policy .....</b>	<b>6:63</b>
<b>SC6.6.1</b>	<b>Introduction .....</b>	<b>6:63</b>
SC6.6.1.1	Relationship to the Planning Scheme .....	6:63
SC6.6.1.2	Purpose .....	6:63
<b>SC6.6.2</b>	<b>Third party consultation .....</b>	<b>6:63</b>
<b>SC6.7</b>	<b>Growth management planning scheme policy .....</b>	<b>6:65</b>
<b>SC6.7.1</b>	<b>Introduction .....</b>	<b>6:65</b>
SC6.7.1.1	Relationship to the Planning Scheme .....	6:65
SC6.7.1.2	Purpose .....	6:65
<b>SC6.7.2</b>	<b>Requirements of growth management documentation.....</b>	<b>6:66</b>
<b>SC6.7.3</b>	<b>Development needs assessment report .....</b>	<b>6:68</b>
SC6.7.3.1	Purpose of a Development needs assessment report .....	6:68
SC6.7.3.2	Preparation of a Development needs assessment report .....	6:68
<b>SC6.7.4</b>	<b>Economic impact assessment report .....</b>	<b>6:70</b>
SC6.7.4.1	Purpose of an Economic impact assessment report	6:70
SC6.7.4.2	Preparation of an Economic impact assessment report .....	6:70
<b>SC6.7.5</b>	<b>Structure plan .....</b>	<b>6:72</b>
SC6.7.5.1	Purpose of a Structure plan .....	6:72
SC6.7.5.2	Preparation of a Structure plan .....	6:72
<b>SC6.7.6</b>	<b>Traffic impact assessment report.....</b>	<b>6:76</b>
SC6.7.6.1	Purpose of a Structure plan .....	6:76
SC6.7.6.2	Preparation of a Traffic impact assessment report ...	6:76
<b>SC6.8</b>	<b>WRC Development manual planning scheme policy .....</b>	<b>6:78</b>
<b>SC6.8.1</b>	<b>Introduction .....</b>	<b>6:78</b>
SC6.8.1.1	Relationship to the Planning Scheme .....	6:78
SC6.8.1.2	Purpose .....	6:78
<b>SC6.8.2</b>	<b>Whitsunday Regional Council (WRC) development manual .....</b>	<b>6:78</b>
<b>SC6.9</b>	<b>Waste management policy .....</b>	<b>6:79</b>
<b>SC6.9.1</b>	<b>Introduction .....</b>	<b>6:79</b>

SC6.9.1.3	Relationship to the Planning Scheme .....	6:79
SC6.9.1.4	Purpose .....	6:79
SC6.9.1.5	Preparation of a Waste management plan .....	6:79
SC6.9.1.6	Waste management plan .....	6:80

## Tables of Schedule 6

Table SC 6.1.1	Planning scheme policy index
Table SC 6.1.1.1:	Scope of the Planning Scheme Policies
Table SC 6.2.2.1	Requirements of environmental features documentation
Table SC6.2.6.4:	Determination of receptor sensitivity and magnitude of change.
Table SC 6.2.6.5:	Assessment of visual impact.
Table SC6.2.7.1	Requirements of Stormwater Quality Documentation .....
Table SC 6.2.8.2.1	Vegetation management plan preparation
Table SC 6.3.2.1	Requirements of heritage documentation
Table SC 6.4.2.1	Requirements of landscaping documentation
Table SC 6.4.4.2.1	Landscaped separation buffer distances
Table SC 6.4.4.2.2	Open space buffer distances
Table SC 6.4.5.2.1	Verge/street trees plant list
Table SC 6.4.5.2.2	Large and/or park trees plant list
Table SC 6.4.5.2.3	Large screening shrubs and windbreaks plant list
Table SC 6.4.5.2.4	Small to medium shrubs plant list
Table SC 6.4.5.2.5	Groundcover, boarders and tufted or clumping plants plant list
Table SC 6.4.5.2.6	Palms, ferns and cycads plant list
Table SC 6.4.5.2.7	Climbers and creepers plant list
Table SC 6.5.2.1	Requirements of natural hazard documentation
Table SC 6.5.3.2.1	Hazard scores and associated fire behaviours for vegetation communities
Table SC 6.5.3.2.2	Hazard scores for slope
Table SC 6.5.3.2.3	Hazard score for aspect
Table SC 6.5.5.2.1	Outcomes for a coastal hazard assessment report
Table SC 6.5.4.2.1	Flood risk
Table SC 6.7.2.1	Requirements of growth management documentation

## Schedule 6 Planning scheme policies

### SC6.1 Planning scheme policy index

The table below lists all the planning scheme policies applicable to the Planning Scheme area.

**Table SC 6.1.1 Planning scheme policy index**

Policy	Planning scheme policy title
SC6.2	Environmental features planning scheme policy
SC6.3	Heritage planning scheme policy
SC6.4	Landscaping planning scheme policy
SC6.5	Natural hazards planning scheme policy
SC6.6	Third party advice or comment planning scheme policy
SC6.7	Growth management planning scheme policy
SC6.8	Whitsunday Regional Council development manual planning scheme policy
SC6.9	Waste Management Policy

#### SC6.1.1 Scope of the Planning Scheme Policies

The table below lists the scope of all the planning scheme policies, providing an indication as to when Council may request an applicant to provide further information in the form of a planning scheme policy.

**Table SC 6.1.1.1: Scope of the Planning Scheme Policies**

Planning Scheme Policy/Report	Scope
<b>Environmental features planning scheme policy</b>	
Acid sulfate soils assessment report	Applications triggering assessment against the Acid sulfate soils overlay code.
Acid sulfate soils management plan	Applications triggering assessment against the Acid sulfate soils overlay code and found to be disturbing acid sulfate soils within the acid sulfate soils assessment report.
Ecological assessment report	Applications triggering assessment against the: <ol style="list-style-type: none"> <li>a) Biodiversity, waterways and wetland overlay code.</li> </ol>
Renewable energy facility visual impact report	Applications triggering assessment against the Renewable energy facilities code.
Stormwater Management Plan	Applications triggering assessment against the Healthy Waters Code.
Vegetation management plan	Applications triggering assessment against the: <ol style="list-style-type: none"> <li>a) Construction management code; or</li> <li>b) Biodiversity, Waterway and wetlands overlay code.</li> </ol>
<b>Heritage planning scheme policy</b>	
Heritage impact assessment report	Applications triggering assessment against the Heritage overlay code.
Heritage management plan	Applications triggering assessment against the Heritage overlay code.
Archaeological management plan	Applications triggering assessment against the Heritage overlay code.

<b>Landscaping planning scheme policy</b>	
Landscaping plan	Applications triggering assessment against the Landscaping code.
Landscaped separation buffer	Applications triggering assessment against the: <ul style="list-style-type: none"> <li>a) Landscaping code; or</li> <li>b) Reconfiguring a lot code; or</li> <li>c) Agricultural land overlay code.</li> </ul>
Planting species list	All development is to have regard for the Planting species list.
<b>Natural hazard planning scheme policy</b>	
Coastal hazard assessment report	Applications triggering assessment against the Coastal environment overlay code.
Flood hazard assessment report	Applications triggering assessment against the Flood hazard overlay code
Landslide hazard (geotechnical) assessment report	Application triggering assessment against the Landslide hazard overlay code.
<b>Growth management planning scheme policy</b>	
Development needs assessment report	At Council discretion. Applications proposing the development of five (5) or more lots (including those lots created under a community title scheme), outside of the existing urban footprint may be required to undertake this report.
Economic impact assessment report	At Councils discretion. Applications proposing the development of Business or Entertainment Activities may be required to undertake this report where the development is: <ul style="list-style-type: none"> <li>a) outside of a designated Centre zone and exceeding a GFA of 150m<sup>2</sup>; or</li> <li>b) within a designated Centre zone, but exceeding the maximum GFA for that Centre zone; or</li> <li>c) within the Mixed use zone and exceeding a GFA of 1,500m<sup>2</sup>.</li> </ul>
Structure plan	At Councils discretion. Applications proposing the development of five (5) or more lots (including those lots created under a community title scheme) may be required to undertake this report.
Traffic impact assessment report	At Councils discretion. Applications proposing the development of the following activities may be required to undertake this report: <ul style="list-style-type: none"> <li>a) Accommodation activities: Five (5) or more lots (including those lots created under a community title scheme); or</li> <li>b) Business, Entertainment, Industry, Recreation or Other Activities: Exceeding a GFA of 1,500m<sup>2</sup>; or</li> <li>c) Community Activities: Exceeding a GFA of 500m<sup>2</sup>.</li> </ul>
<b>Waste Management planning scheme policy</b>	
Waste Management Policy	Applications proposing development of: <ul style="list-style-type: none"> <li>(a) residential subdivision with 4 or more lots;</li> </ul>

	<ul style="list-style-type: none"><li>(b) Multiple dwelling;</li><li>(c) Short-term accommodation;</li><li>(d) Relocatable home park;</li><li>(e) Retirement facility;</li><li>(f) Tourist park;</li><li>(g) Rooming accommodation;</li><li>(h) Resort complex; or</li><li>(i) Mixed use development with two or more uses onsite.</li></ul>
--	--

## **SC6.2 Environmental features planning scheme policy**

### **SC6.2.1 Introduction**

#### **SC6.2.1.1 Relationship to the Planning Scheme**

- (1) This planning scheme policy provides:
  - (a) information the Council may request for a development application; and
  - (b) guidance or advice about satisfying an assessment benchmark which identifies this planning scheme policy as providing that guidance or advice.

#### **SC6.2.1.2 Purpose**

- (1) The purpose of this planning scheme policy is to provide information, guidance and advice for satisfying the assessment benchmarks for the preparation of a site specific:
  - (a) Acid sulfate soil assessment report;
  - (b) Acid sulfate soils management plan;
  - (c) Ecological assessment report;
  - (d) Renewable energy facility visual impact assessment report;
  - (e) Stormwater management plan; and
  - (f) Vegetation management plan.

#### **SC6.2.1.3 Environmental features overlay mapping**

- (1) Environmental features overlay mapping has been prepared for the local government area, showing the areas of environmental and waterway (water quality) health. This mapping has been prepared in accordance with the requirements of the State Planning Policy (SPP). The specific environmental and waterways overlays to which this PSP applies are:
  - (a) Acid sulphate soils overlay code. Mapping:
    - (i) identifies the Known presence of acid sulfate soils for; Land at or below 5m AHD and Land above 5m AHD and below 20m AHD sub-categories; and
    - (ii) has been prepared at a scale at which a site specific investigation of acid sulfate soils will be necessary to determine the presence and extent of acid sulfate soil on a site (Acid sulfate soils assessment report) and the necessity for an Acid sulfate soils management plan;
  - (b) Biodiversity, waterways and wetlands overlay code. Mapping:
    - (i) identifies Regulated vegetation, Wildlife habitat, Protected and Regulated vegetation features; and
    - (ii) is not a substitute for a site based assessment. A site specific Ecological assessment report should be undertaken and prepared to verify, specific to the site, the presence of Matters of environmental significance on a site and necessity for a Vegetation management plan;

- (iii) identifies Matters of state environmental significance: High ecological value waters (watercourse), High ecological value waters (wetlands), High ecological significance wetlands, Marine parks and Declared fish habitat area and Matters of local environmental significance: Stream order 1 - 5 sub-categories; and
- (iv) is not a substitute for a site based assessment. A site specific Ecological assessment report should be undertaken and prepared to verify, specific to the site, the presence of matters of environmental significance on a site and necessity for a Vegetation management plan.

## SC6.2.2 Requirements of environmental features documentation

- (1) Environmental features documentation is to be prepared in a clear and concise manner, consistent with the elements identified in Table SC 6.2.2.1 (Requirements of Environmental features documentation) below, as well as any specific requirements identified in the relevant sub-sections of this report.

**Table SC 6.2.2.1 Requirements of environmental features documentation**

Documentation	Preparation	Report requirements
Acid sulfate soils assessment report	<ul style="list-style-type: none"> <li>Prepared by a suitably qualified professional with appropriate technical expertise in the field of acid sulfate soils identification and management.</li> <li>Consultation with other entities may also be necessary including Council, State government and other relevant agencies or individuals.</li> </ul>	<ul style="list-style-type: none"> <li>A site specific Acid sulfate soils assessment report may be requested to provide additional information to Council.</li> <li>A site specific Acid sulfate soil assessment report is to be prepared in accordance with SC6.2.3 (Acid sulfate soils assessment report).</li> <li>An Acid sulfate soils assessment is to be prepared in accordance with the Queensland Acid Sulfate Soils Technical manual (Queensland Government, 2014), or any later guideline as agreed by Council and is to be provided as part of the site specific Acid sulphate soil assessment report.</li> <li>All investigations, testing and design should be undertaken in accordance with industry practice and the provisions of relevant Australian Standards.</li> </ul>
Acid sulfate soils management plan	<ul style="list-style-type: none"> <li>Prepared by a suitably qualified professional with appropriate technical expertise in the field of acid sulfate soils identification and management.</li> <li>Consultation with other entities may also be necessary including Council, State government and other relevant agencies or individuals.</li> </ul>	<ul style="list-style-type: none"> <li>A site specific Acid sulfate soils management plan may be requested to provide additional information to Council.</li> <li>A site specific Acid sulfate soil management plan is to be prepared in accordance with:               <ol style="list-style-type: none"> <li>SC6.2.4 (Acid sulfate soils management plan); and</li> <li>State Planning Policy – State interest guideline: Water quality, August 2014, or any later guideline as agreed by Council.</li> </ol> </li> </ul>
Ecological assessment report	<ul style="list-style-type: none"> <li>Prepared by a suitably qualified professional with a relevant tertiary qualification in ecology, conservation biology or environmental planning and at least 5 years' experience in ecology surveys, assessment and reporting.</li> <li>Consultation with other entities may also be necessary including Council, State</li> </ul>	<ul style="list-style-type: none"> <li>A site specific Ecological assessment report may be requested to provide additional information to Council.</li> <li>A site specific Ecological assessment report is to be prepared in accordance with SC6.2.5 (Ecological assessment report).</li> </ul>

	government and other relevant agencies or individuals.	
Renewable energy facility visual impact assessment report	<ul style="list-style-type: none"> <li>Prepared by a suitably qualified professional with appropriate technical expertise in visual impact assessment.</li> <li>Consultation with other entities may also be necessary including Council, State government and other relevant agencies or individuals (eg business owners)</li> </ul>	<ul style="list-style-type: none"> <li>A site specific Renewable energy facility visual impact assessment report in accordance with SC6.2.6 may be requested to provide additional information to Council.</li> </ul>
Stormwater Quality Management Plan	<ul style="list-style-type: none"> <li>Prepared by a suitably qualified professional with appropriate technical expertise in stormwater assessment</li> <li>Consultation with other entities may also be necessary including Council, State government and other relevant agencies or individuals (eg business owners)</li> </ul>	<ul style="list-style-type: none"> <li>A site specific Stormwater Quality Management Plan may be requested to provide additional information to Council.</li> <li>A site specific stormwater quality management plan is to be prepared in accordance with SC6.2.7 (Stormwater Management Plan) and the Whitsunday Regional Council Stormwater Quality Guidelines, or any later guideline as agreed by Council.</li> </ul>
Vegetation management plan	<ul style="list-style-type: none"> <li>Prepared by a suitably qualified professional with a relevant tertiary qualification in ecology, conservation biology or environmental planning and at least 5 years' experience in vegetation management, assessment and reporting.</li> <li>Consultation with other entities may also be necessary including Council, State government and other relevant agencies or individuals.</li> </ul>	<ul style="list-style-type: none"> <li>A site specific Vegetation management plan may be requested to provide additional information to Council.</li> <li>A site specific Vegetation management plan is to be prepared in accordance with SC6.2.8 (Vegetation management plan).</li> </ul>

## **SC6.2.3 Acid sulfate soils assessment report**

### **SC6.2.3.1 Purpose of an Acid sulfate soils assessment report**

- (1) An Acid sulfate soils assessment report is required to:
  - (a) quantify the extent and severity of acid sulfate soils for a particular site;
  - (b) ensure appropriate methods are implemented to mitigate or avoid the disturbance of acid sulfate soils; and
  - (c) provide information and guidance to support the outcomes required by the Acid sulfate soils overlay code.

### **SC6.2.3.2 Preparation of an Acid sulfate soils assessment report**

- (1) The site-specific Acid sulfate soils assessment report is to include an acid sulfate soils assessment, as detailed in Table SC 6.2.2 (Requirements of environmental features documentation) of this planning scheme policy.
- (2) An Acid sulfate soil assessment report is to:
  - (a) explain the methodology and findings of the acid sulfate soils assessment to determine the presence, extent and severity of any actual acid sulfate soils or potential acid sulfate soils on the site;
  - (b) evaluate the potential for harm to the environment or to constructed assets as a result of the development; and
  - (c) make recommendations as to whether management measures are needed.
- (2) If the acid sulfate soil assessment report finds that acid sulfate soils will be affected by the development, then an Acid sulfate soil management plan is to be prepared in accordance with SC6.2.4 (Acid sulfate soils management plan).

## **SC6.2.4 Acid sulfate soils management plan**

### **SC6.2.4.1 Purpose of an Acid sulfate soils management plan**

- (1) An Acid sulfate soils management plan is required to:
  - (a) explain how acid sulfate soils will be managed on the site to minimise or prevent harm to the environment or to constructed assets; and
  - (b) provide information and guidance to support the outcomes required by the Acid sulfate soil overlay code.

### **SC6.2.4.2 Preparation of an Acid sulfate soils management plan**

- (1) An Acid sulfate soil management plan is to include at a minimum:
  - (a) a two-dimensional map of the actual or potential acid sulfate soils to the depth of disturbance;
  - (b) details that reflect potential on-site and off-site impacts of the disturbance on the soil and the groundwater levels;
  - (c) the methods that will be used to avoid, treat or otherwise manage acid sulfate soils, including the contained on-site management and treatment of potential and actual acid sulfate soils;
  - (d) the details of any pilot project or field trial to be undertaken to prove the effectiveness of any new technology or innovative management practice being proposed;
  - (e) details of the management of the height of the groundwater table on-site and off-site both during and after construction;
  - (f) details of all soil and water monitoring, both manual and automated, to be performed during and after treatment, and including verification testing of soils;
  - (g) details of the handling and storage of neutralising agents;
  - (h) details of contained on-site treatment and management of potentially contaminated stormwater run-off, and leachate including details of groundwater management associated with the works both in the short and long term;
  - (i) a description of contingency measures to be implemented on and off the site if the management procedures prove to be unsuccessful and acid is generated or leachate problems occur; and
  - (j) details of the treatment and management of surface drainage waters for disturbed acid sulfate soils.
- (2) The Acid sulfate soil management plan is to provide for the ongoing management and monitoring of impacts of acid sulfate soil material throughout the construction and operation of the project and describe the construction schedules and environmental management procedures.
- (3) The development is to be staged so that the potential impact of any area disturbed at any one time is limited and easily managed. Documentation containing the schedule of monitoring is to be made available for Council inspections.

- (4) Action is to be taken to prevent or minimise any adverse impacts on surface water, groundwater, the site and surrounding areas. These actions are to be documented in the acid sulfate soil management plan and include:
- (a) objectives and outcomes;
  - (b) management measures;
  - (c) performance indicators;
  - (d) elements to be monitored;
  - (e) a monitoring schedule;
  - (f) contingency plans;
  - (g) responsibilities;
  - (h) reporting and review requirements; and
  - (i) training arrangements.

## **SC6.2.5 Ecological assessment report**

### **SC6.2.5.1 Purpose of an Ecological assessment report**

- (1) An Ecological assessment report is required to:
  - (a) quantify the matters of environmental significance on a particular site;
  - (b) ensure appropriate methods are implemented to appropriately protect, manage or restore matters of environmental significance on the site; and
  - (c) provide information and guidance to support the outcomes required by the Biodiversity, waterways and wetlands overlay code.

### **SC6.2.5.2 Undertaking an Ecological assessment report**

- (1) An Ecological assessment report is to incorporate a tree survey plan in accordance with SC6.2.5.3 (Preparation of a Tree survey plan), which identifies all the trees on the development site.
- (2) Prior to any field survey work commencing, records are to be investigated to identify likely regional ecosystems, flora, and fauna species (including weed and pest animal species) which may occur on the site or on adjoining lands within a one kilometre radius of the site. Records to be investigated include:
  - (a) research reports;
  - (b) local knowledge (such as from local catchment and environment groups);
  - (c) databases, such as the Council and Queensland Government regional ecosystem mapping, and flora and fauna records held by the Queensland Government (Wildnet), Queensland Museum and Queensland Herbarium; and
  - (d) published literature.
- (3) The field survey is to assess the presence or likely presence of ecological features, significant vegetation communities, and flora and fauna species (including weed and pest animal species) on the site. Specifically, it should:
  - (a) incorporate coverage of all major habitat types on the site;
  - (b) use survey techniques suited to a diversity of flora and fauna; and
  - (c) consider seasonal variations, survey duration and climatic conditions.
- (4) Ecological features and processes are essential to the conservation of biodiversity and the maintenance of ecosystem services. Some examples of ecological features and processes which need to be identified on or adjoining the site are:
  - (a) areas that contain nationally and internationally important flora, fauna, ecological communities and heritage places as identified in the *Environment Protection and Biodiversity Conservation Act 1999*;
  - (b) areas declared as Fish Habitat Areas under the *Fisheries Act 1994*;
  - (c) areas prescribed under the *Nature Conservation Act 1992*, including areas subject to an Interim Conservation Order and areas subject to a conservation plan;

- (d) areas identified as having conservation significance under the *Coastal Protection and Management Act 1995*;
  - (e) important habitat features or evidence of fauna species, such as trees supporting scratch marks and hollows, stags, scats, tracks and other traces, fruit and seed falls, fauna trails, fallen logs, termite mounds, ground diggings, rock outcrops, nests in banks and roost, nest and den trees;
  - (f) areas that would be suitable for habitat restoration, consolidating any existing habitat on site or on adjoining sites.
- (5) To identify flora and vegetation communities, plot or transect-based survey methods are to be used when establishing a flora species inventory, weed survey, or searching for significant flora species. All vegetation communities, including wetlands and, within these, all microhabitats (such as dry gullies) are to be identified. The regional ecosystem type is to be classified and the age, structure, composition and condition of the vegetation is to be assessed. Plans and literature may also have flora and fauna records.
- (6) For fauna surveys, a minimum of 4 days and 4 nights of survey time are recommended to minimise any sampling duration influences within any given sampling period. Regard must also be had for any migratory species which may not be present but habitually use the location. In circumstances where less sampling effort is proposed, appropriate justification is to be provided in the ecological assessment report. The biodiversity survey principles to be considered when undertaking a fauna survey include:
- (a) survey methodology which accounts for habitat diversity and species requirements;
  - (b) survey design to minimise factors which may reduce the quality of the survey results;
  - (c) data is collected in a consistent format; and
  - (d) ecological investigations in accordance with best-practice research ethics.
- (7) Fauna data is to be supported by the start and end dates of the survey, coordinates of the survey location, scientific and common name of identified species and the location precision.
- (8) Identify any existing impacts or threatening processes to the ecological features, vegetation communities (regional ecosystems) and flora and fauna species on the site.
- (9) Outline the likely impacts of development on the ecological features and flora and fauna species. Examples of spatial and temporal impacts from development include:
- (d) loss or fragmentation of habitat;
  - (e) decrease or change in structure, composition, complexity and connectivity of vegetation;
  - (f) increased edge effects, such as noise and light;
  - (g) earthworks and installation of infrastructure, such as retaining walls, paths, roads, stormwater treatment devices;

- (h) weed and pest animal invasion;
- (i) changes to fire risks and regimes;
- (j) changes to flow regimes, nutrients, sediment and pollutant loads;
- (k) barriers to safe wildlife movement such as roads or fences; and
- (l) introduction of domestic animals.

### **SC6.2.5.3 Preparation of a Tree survey plan**

- (1) A Tree survey plan forms part of the Ecological assessment report (SC6.2.5.4 Preparation of an Ecological assessment report) and involves identifying, assessing and surveying all trees on a site and provides a description of the site and the proposed works.
- (2) The Tree survey plan comprises a map and a supporting table or report outlining the location and other attributes of trees located on the site. It is to incorporate the following information:
  - (a) a scaled tree survey map overlaid on the development layout, identifying the location of:
    - (i) individual trees, ensuring each tree is numbered and the area of the canopy spread is shown indicatively;
    - (ii) those trees proposed for retention;
    - (iii) those trees proposed for removal; and
    - (iv) any tree protection zones;
  - (b) a table which includes:
    - (i) the number for each tree identified on the tree survey map;
    - (ii) tree species (botanical and common names);
    - (iii) height;
    - (iv) diameter at breast height;
    - (v) canopy spread (in square metres);
    - (vi) condition/health;
    - (vii) evidence of fauna use or habitat value including scratch marks, hollows, nests, termites and scats;
    - (viii) trees to be removed or root zones to be impacted; and
    - (ix) trees to be retained;
  - (c) photographs of the site, key tree species and evidence of fauna use, where relevant; and
  - (d) any other supporting information provided by a qualified arborist.

### **SC6.2.5.4 Preparation of an Ecological assessment report**

- (1) The Ecological assessment report informs the design of the development layout and footprint and is to be completed prior to the development design and layout.
- (2) The level of detail contained within the Ecological assessment report will vary, reflecting the nature of the development and site attributes. The report is to include at a minimum:
  - (a) a description of the methodology used to complete the assessment:
    - (i) provide a full description of the field survey methodology used and assumptions made;

- (ii) detail all background investigations undertaken including literature reviewed, and recognised specialists, authorities and local naturalists consulted or referenced; and
  - (iii) reports that rely primarily on desktop research with little or no field-based work are not acceptable;
- (b) a description and map of the ecological features and processes, vegetation communities and flora and fauna species of the site and adjacent lands will at a minimum:
  - (i) identify and detail ecological features and provide a map displaying the location and extent of the ecological features. This is referred to as an ecological features map. Appropriate photographs and figures will enable the identification and location of ecological features on the ground;
  - (ii) in addition to identifying ecological features, the Ecological Features map is also to include:
    - (A) 1m contours for the existing site topography;
    - (B) areas included in the Biodiversity, waterways and wetlands overlay map;
    - (C) location of waterway corridors and wetlands as shown on the Waterway and wetlands overlay map;
    - (D) existing buildings and infrastructure such as roads or sewer lines; and
    - (E) nature and extent of any vegetation protected under the *Vegetation Management Act 1999*;
  - (iii) describe key ecological processes occurring on the site and adjacent lands;
  - (iv) include appropriate photographs, figures and maps that will enable the identification and location of ecological features on the ground;
  - (v) accurately map and describe the vegetation communities, (remnant and non-remnant vegetation) in the site and on adjacent lands. Include details such as age, structure, composition and condition of vegetation communities on the site and on adjacent lands;
  - (vi) describe and map accurately the terrestrial and aquatic flora species and vegetation communities (including details such as age, structure, composition, condition, State/national significance and regional ecosystem status) in the site and on adjacent lands. A table outlining the location and attributes of trees on the development site should also be provided;
  - (vii) document and describe the presence of any flora species listed as threatened under Commonwealth or State legislation;
  - (viii) provide any past flora and fauna records of the site and adjoining lands within a 1km radius of the site. Records include research reports, local knowledge and databases, such as the Queensland Museum and Queensland Herbarium records;
  - (ix) identify terrestrial and aquatic fauna species present or likely to be present within the site and adjacent lands;
  - (x) prepare an appropriately scaled map identifying the location of key habitat features or evidence of fauna species, including trees supporting scratch marks and hollows, stags, fruit and seed falls, fauna trails, fallen logs, termite mounds, ground diggings, rock outcrops, nests in banks and roost, nest and den trees; and
  - (xi) document and describe the presence of any fauna species.
- (c) document potential development impacts on ecological features and processes including:
  - (i) an outline of the proposed development:
    - (A) nature of the land use;

- (B) the extent of the development footprint and details of the site layout; and
    - (C) development design including the building height in metres, location of any outdoor lighting, audio systems or other noise generating activities;
  - (ii) identification of the proposed hours of operation if non-residential including:
    - (A) the number of people anticipated on site at various times during the day and night; and
    - (B) the number and type of vehicle movements anticipated on site during the ongoing operation phase;
  - (iii) for the construction phase, details of the sequence of any proposed vegetation clearing, type of construction machinery and proposed barriers to restrict site access to ecologically sensitive areas;
  - (iv) differentiation between the impacts likely to occur during the construction of the development versus those impacts resulting from the ongoing operation of the development (including cumulative impacts of the development); and
  - (v) details of potential spatial (on-site and off-site) and temporal (short- and long-term) direct and in-direct impacts from the development on flora and fauna species and vegetation communities, including consideration of the construction and operational phases of the development. Specifically discuss the likely consequences of the identified impacts for the site and adjacent lands;
  - (vi) the degree of confidence with which the impacts of the action are known and understood;
- (d) detail how the layout of the development avoids impacts to the ecological features and processes and significant flora and fauna species and outline the impact mitigation measures that will be undertaken to reduce the impacts to ecological features and processes by:
  - (i) clearly demonstrating how the proposed mitigation strategies will enable the development to meet the nature conservation obligations as described in the relevant statutory planning mechanisms; and
  - (ii) providing information about development designs to mitigate impacts to ecological features and processes, such as:
    - (A) protecting ecological connectivity;
    - (B) enhancing habitat extent and condition; and
    - (C) rehabilitating degraded areas.

## **SC6.2.6 Renewable Energy Facility Visual Impact Assessment**

### **SC6.2.6.1 Purpose of a Renewable Energy visual impact assessment**

- (1) A Renewable energy facility visual impact assessment report is required to:
  - (a) Assess sensitive receptors and roads visual exposure to a proposed Renewable energy facility;
  - (b) Assess the visual impact of a Renewable energy facility on sensitive receptors, roads and public areas; and
  - (c) Outline mitigation strategies to reduce the visual impact on public areas and sensitive receptors, such as Accommodation activities;

### **SC6.2.6.2 Undertaking a Renewable energy facility visual impact assessment**

- (1) A Renewable energy visual impact assessment involves an assessment of a proposed development to determine its potential impact upon surrounding sensitive receptors and roads, including potential for glint or glare from solar panels and suitability as a land use within the landscape;
- (2) In developing a Renewable energy visual impact assessment, due regard should be given to the location of surrounding sensitive receptors, roads, topography, vegetation, solar panel type and development layout; and
- (3) The steps to be followed and information provided when preparing a Renewable energy visual impact assessment are outlined below:

#### **Step 1: Describe the project and its visual components**

- (a) Description of the project, including site layout, landscaping, major electricity infrastructure, lighting, scale and type of solar panel to be utilised (where applicable), such as fixed, dual axis or single axis trackers;

#### **Step 2: Evaluate visual environment, landscape of development site and surrounding area**

- (b) Provide photos and descriptions of key elements within the surrounding landscape to provide local context, including existing infrastructure, topography, vegetation, aesthetic landforms, buildings, public spaces and land uses, having regard to potential future residential growth;
- (c) Assess the surrounding Landscape character type, surrounding high or medium amenity areas and scenic gateways based upon scenic preferences and mapping from the Whitsunday Scenic Amenity Study, refined by applying site-specific analysis of local context;

Note - Landscape character types are defined within Table 4 and high amenity areas are defined within Appendices of the Whitsunday Scenic Amenity Study online at <http://www.whitsunday.qld.gov.au/566/Studies-and-Superseded-Planning-Schemes>. GIS Tab files of high, medium and low amenity areas can be provided at request.

#### **Step 3: Assess visual receptor sensitivity within the study area and assess impact of development upon viewpoints**

- (d) Identify surrounding scenic corridors and sensitive receptors, such as Accommodation activities, future residential growth areas and public roads that have visibility of the proposed Renewable energy facility;

Note – Scenic corridors defined by AO1.2 of the Renewable energy facilities code include Gregory Cannon Valley Road, Conway Road, Crystal Brook Road, or Bowen-Developmental Road between Bogie River and Strathmore Road

- (e) If necessary, undertake a field of view analysis to provide a detailed assessment of the impact of development intruding upon a scenic corridor or sensitive receptor’s views of high amenity landscapes or key landscape features;
- (f) Assess receptor sensitivity based upon Table SC6.2.6.1;

**Step 4: Identify potential impacts upon sensitive receptors, scenic corridors and roads,**

- (g) Operational aspects of the Renewable energy facility, including construction and operation, with regard to lighting, vegetation clearing and movement of heavy machinery;
- (h) Glare or glint from solar panels on sensitive receptors and public roads at all times of the day and year based upon the angle of the fixed or moving panels, including:
  - i. frequency; and
  - ii. intensity;
- (i) Assess magnitude of change of the proposed development upon view corridors of high amenity landscapes or landscape features viewed by identified sensitive receptors or scenic corridors in accordance with Table SC6.2.6.2;
- (j) Summarise visual impact upon sensitive receptors in terms of intrusion upon high or medium amenity landscapes, landscape features and potential for glint and glare from solar panels upon sensitive uses and public roads utilising Table SC 6.2.6.3;

**Step 5: Renewable energy facility visual impact mitigation strategies**

- (k) Specify mitigation strategies to limit the potential visual impact as a result of glare or glint from solar panels upon sensitive receptors or public roads;
- (l) Specify mitigation strategies to limit intrusion upon views of high amenity landscapes from sensitive receptors or scenic corridors identified by the Whitsunday Scenic Amenity Study; and
- (m) Summarise the potential visual impact following the implementation of mitigation measures.

**Table SC6.2.6.4: Determination of receptor sensitivity and magnitude of change.**

Relative sensitivity	Receptor which may be exposed to the development	Magnitude of change	Explanation
High	<ul style="list-style-type: none"> <li>• Elevated Accommodation activities that maintain a predominately open view of high amenity areas or key landscape characteristics that are intruded upon by the development; and</li> <li>• Motorists and passengers on Scenic corridors.</li> </ul>	High	<ul style="list-style-type: none"> <li>• Loss or major alteration of key landscape features identified as high amenity landscape when viewed from sensitive uses; and</li> <li>• Glint and glare from solar panels affecting open views of sensitive uses or users of arterial roads.</li> </ul>

Medium	<ul style="list-style-type: none"> <li>Accommodation activities that have views from windows or partially obscured views of high amenity areas or key landscape characteristics that are intruded upon by the development; or</li> <li>Motorists and passengers on arterial roads.</li> </ul>	Medium	<ul style="list-style-type: none"> <li>Loss or major alteration of key landscape features or medium amenity landscapes when viewed from sensitive uses; and</li> <li>Glint and glare from solar panels affecting partially obscured views or windows of sensitive uses or users of rural roads.</li> </ul>
Low	<ul style="list-style-type: none"> <li>All other receptors</li> </ul>	Low	<ul style="list-style-type: none"> <li>Minor loss of or alteration to one or more key features of the landscape character or medium amenity area; and</li> <li>No glint or glare from solar panels affecting sensitive uses or any road users.</li> </ul>

Note – Scenic corridors defined by AO1.2 of the Renewable energy facilities code include Gregory Cannon Valley Road, Conway Road, Crystal Brook Road, or Bowen-Developmental Road between Bogie River and Strathmore Road. Key landscape features may include aspects, such as valleys or gorges, mountains, waterfalls, waterways or significant trees. High amenity and medium amenity areas are defined within Appendices of the Whitsunday Scenic Amenity Study online at <http://www.whitsunday.qld.gov.au/566/Studies-and-Superseded-Planning-Schemes>

**Table SC 6.2.6.5: Assessment of visual impact.**

Assessment of Visual Impact		Sensitivity to visual change		
		High	Medium	Low
Magnitude of change to views	High	Major	Major	Moderate
	Medium	Major	Moderate	Minor
	Low	Moderate	Minor	Minor

## SC6.2.7 Stormwater management plan

### SC6.2.7.1 Purpose

- (1) The purpose of this planning scheme policy is to provide information, guidance and advice for satisfying the assessment benchmarks for the preparation of a site specific:
- (a) a stormwater quality management plan (SQMP).

### SC6.2.7.2 Requirements of stormwater quality documentation

- (1) Stormwater documentation is to be prepared in a clear and concise manner, consistent with the elements identified in Table SC6.2.7.1 (Requirements of Stormwater documentation) below, as well as any specific requirements identified in the relevant sub-sections of this report.

**Table SC6.2.7.1 Requirements of Stormwater Quality Documentation**

Documentation	Preparation	Report requirements
Stormwater Quality Management Plan & associated drawings	<ul style="list-style-type: none"> <li>• Prepared by a suitably qualified professional with appropriate technical expertise in stormwater assessments.</li> <li>• Consultation with other entities may also be necessary including Council, State government and other relevant agencies or individuals (e.g. business owners).</li> </ul>	<ul style="list-style-type: none"> <li>• Stormwater Quality Management Plan may be requested to provide additional information to Council.</li> <li>• A site specific stormwater quality management plan is to be prepared in accordance with the Whitsunday Regional Council Stormwater Quality Guidelines, or any later guideline as agreed by Council</li> </ul>

### SC6.2.7.3 Preparation of a Stormwater Quality Management Plan (SQMP)

- 1) A stormwater quality management plan is required to:
  - (a) provide guidance on the policy and standards required in relation to the provision of stormwater infrastructure for new development; and
  - (b) ensure stormwater infrastructure design and construction satisfies Council's requirements and environmental and safety expectations.
- 2) A stormwater quality management plan comprises of the following for MCU/ROL applications:

Section	Contents
Cover page	Development name and reference
Document information page	Table outlining information relevant to the development of the SQMP, including document title (reference number, date and version), document authors and reviewers, suitably qualified persons details (qualifications and experience), names of the project team and signature and name of the client.
Table of contents	Structure of the SQMP.
Introduction	Description of the proposed development (works, address and RP) and purpose of the SQMP.
Previous reports	Summary of other reports which deal with stormwater management that are superseded by this report
Related reports	Summary of reports (such as waterway assessments and soil investigations) that should be read in conjunction with the SQMP.

Previous approvals or requests for information (if relevant)	Details of any previous approvals or requests for information for the development site.
Site description	<p>Description of the development site including details of topography, geology, relevant hydrological/ drainage features, existing natural features, imperviousness etc.</p> <p>Site survey details including spot levels, contours, boundaries, waterways, vegetation (including regional ecosystem mapping), easements and other relevant site features.</p> <p>Description of site constraints.</p>
Development description	Description of the proposed development including land use, scale, densities, site coverage (percent impervious), lawful point of discharge and general urban design.
Stormwater management objectives	List of all the stormwater management objectives (see Section 2) which apply to the development. Justification for any objectives not adopted.
Stormwater management strategy	<p>Description of the selected stormwater management initiatives required to comply with each objective applicable to the development. This should include figures providing conceptual catchments, location and scale of the stormwater management initiatives. It must demonstrate that sufficient space is available for the stormwater management initiatives. This includes both horizontal and vertical space. The proposed system must be able to drain.</p> <p>If the proponent is proposing a bioretention system for the site to comply with the stormwater quality design objectives, they may, if they wish, adopt a filter media sized at 1.5% of the catchment, and allow a total of 3 times this area for the total footprint of the system.</p> <p>If the proponent is proposing a vegetated stormwater asset other than a bioretention system (typically a wetland or swale) they may, if they wish, adopt a size of that system's treatment area using MUSIC and allow a total of 3 times this area for the total footprint of the system.</p> <p>Note that the above does not negate the need to demonstrate that sufficient vertical space has been allowed and that the system can freely drain.</p>
Assessment, modelling and calculations	Detailed description, calculations and models used to determine the stormwater management strategy and compliance with the relevant objectives.
Lifecycle costs (if relevant)	Where the stormwater management strategy involved proprietary devices, lifecycle costs shall be provided.
Conclusion	Relevant concluding information.
References	List of reference documents.
Appendix 2	Where MUSIC modelling has been completed, completed versions of the relevant reporting forms contained in Appendix A of the MUSIC Modelling Guidelines (Water by Design, 2016) shall be provided.
Other appendices (if relevant)	Other appendices as relevant.

a) all stormwater models and calculations used in the creation of the SQMP and development application

3) A stormwater quality management plan comprises of the following for OPW applications:

Section	Contents
Cover page	Development name and reference
Document information page	Table outlining information relevant to the development of the SQMP, including document title (reference number, date and version), document authors and reviewers, suitably qualified persons details (qualifications and experience), names of the project team and signature and name of the client.
Table of contents	Structure of the SQMP.
Introduction	Description of the proposed development (works, address and RP) and purpose of the SQMP.
Previous reports	Summary of other reports which deal with stormwater management that are superseded by this report
Related reports	Summary of reports (such as waterway assessments and soil investigations) that should be read in conjunction with the SQMP.
Previous approvals or requests for information (if relevant)	Details of any previous approvals or requests for information for the development site.
Site description	Description of the development site including details of topography, geology, relevant hydrological/ drainage features, existing natural features, imperviousness etc.  Site survey details including spot levels, contours, boundaries, waterways, vegetation (including regional ecosystem mapping), easements and other relevant site features.  Description of site constraints.
Development description	Description of the proposed development including land use, scale, densities, site coverage (percent impervious), lawful point of discharge and general urban design.
Stormwater management objectives	List of all the stormwater management objectives (see Section 2) which apply to the development. Justification for any objectives not adopted.
Stormwater management strategy	Description of the selected stormwater management initiatives required to comply with each objective applicable to the development. This should include a scale figures providing conceptual catchments, location and scale of the stormwater management initiatives.
Assessment, modelling and calculations	Detailed description, calculations and models used to determine the stormwater management strategy and compliance with the relevant objectives.
Lifecycle costs (if relevant)	Where the stormwater management strategy involved proprietary devices, lifecycle costs shall be provided.
Construction, establishment, bonding and handover	Detailed description of the construction, establishment, bonding and handover processes to be used (see Section 7)
Conclusion	Relevant concluding information.
References	List of reference documents.
Appendix 1	Detailed engineering and landscape design drawings shall be shown.
Appendix 2	Where MUSIC modelling has been completed, completed versions of the relevant reporting forms contained in Appendix A of the MUSIC Modelling Guidelines (Water by Design, 2016) shall be provided.
Other appendices (if relevant)	Other appendices as relevant.

a) detailed engineering and landscape drawings ; and

- b) working copies of all stormwater models and calculations used in the creation of the SQMP and development application; and
- c) suitably qualified person certification.

#### **SC6.2.7.4 Preparation of a Stormwater Quality Management Plan Additional Guidelines**

For the purposes of the performance outcomes and acceptable outcomes in the Healthy Waters code, the following are relevant guidelines for preparation of a stormwater quality management plan: -

- a) Whitsunday Regional Council Stormwater Quality Guideline.

## SC6.2.8 Vegetation management plan

### SC6.2.8.1 Purpose of a Vegetation management plan

- (1) A Vegetation management plan is required to ensure appropriate methods are implemented to appropriately protect against, manage or restore the disturbance of vegetation before, during and after construction works on a site.
- (2) A Vegetation management plan may be required prior to or as a condition of a development approval; in which case it is required to be lodged before the commencement of site works or any interference with vegetation.

### SC6.2.8.2 Preparation of a Vegetation management plan

- (1) A Vegetation management plan is to comprise a plan of layout and supporting text.
- (2) The plan of layout is to include the following standard features as a minimum:
  - (a) cadastral and property boundaries and dimensions adequate to interpret the plan;
  - (b) layout of development, including existing and proposed alignments of services and infrastructure;
  - (c) location and description of vegetation to be retained, cleared and restored, including drainage lines, waterway corridors, wetlands and other ecological features;
  - (d) location of protective fences or other vegetation protection measures such as designated vehicle access, signage, tree guards and retaining clumps of trees for wind and storm protection;
  - (e) contours (including areas for proposed filling and excavation);
  - (f) location and type of erosion measures;
  - (g) location of dedicated work areas including stockpile and disposal sites; and
  - (h) location of machinery access ways.
- (3) The supporting text is a critical component of a Vegetation management plan and reports on the four main steps of vegetation management processes, namely:
  - (a) project management;
  - (b) vegetation protection;
  - (c) clearing and disposal; and
  - (d) rehabilitation and maintenance.
- (4) Each step is presented in Table SC 6.2.6.2.1 (Vegetation management plan preparation) with suggested approaches as to how to achieve the key aims and outcomes.

**Table 6.2.8.2.1 Vegetation management plan preparation**

Key aims or outcomes	Suggested approach
A. Project Management	

<ul style="list-style-type: none"> <li>• To formulate and implement vegetation management actions.</li> <li>• To clearly identify objectives, methods and reporting lines.</li> <li>• To inform all relevant people, companies and workers of their responsibilities.</li> </ul>	<ul style="list-style-type: none"> <li>• Vegetation management plan to be prepared in conjunction with engineering requirements.</li> <li>• Vegetation management to be an integral part of the construction and operational phases.</li> <li>• Nominate a person with responsibility for overseeing development works (such as the site supervisor), a person responsible for implementing vegetation management plan actions on site, and a person for point-of-contact for the Council.</li> <li>• Instruct all workers and contractors as to their role in vegetation management.</li> <li>• Provide the method of assessing compliance with the vegetation management plan.</li> </ul>
<b>B. Vegetation protection</b>	
<ul style="list-style-type: none"> <li>• To effectively protect vegetation during construction and operational phases.</li> </ul>	<ul style="list-style-type: none"> <li>• Identify vegetation for removal and protection on a vegetation retention plan.</li> <li>• Refer to appropriate Australian Standards e.g. AS 4970-2009 (Protection of trees on development sites), and AS 4373-2007 (Pruning of amenity trees).</li> <li>• Implement vegetation protection measures during construction. These commonly include designated vehicle access ways, signage, protective barrier fences, silt fences, tree guards and dedicated work areas. Establish these measures prior to works commencing and maintain the measures throughout the construction phase.</li> <li>• Protect the root zones of individual trees or clumps of trees from compaction, filling, stockpiling or excavation. Refer to AS 4373-2007 (Pruning of amenity trees).</li> <li>• Identify a replacement formula for trees which are damaged.</li> </ul>
<b>C. Clearing and disposal</b>	
<ul style="list-style-type: none"> <li>• To minimise the adverse impacts of vegetation clearance.</li> <li>• To maximise recycling or re-use of cleared vegetation.</li> <li>• To minimise the impacts on existing fauna.</li> </ul>	<ul style="list-style-type: none"> <li>• Clearly identify and indicate on a plan the area of vegetation proposed to be cleared in relation to tree protection zones and structural root protection zones.</li> <li>• Use clearing methods that will not damage adjacent protected vegetation and that will minimise soil profile disturbance. Match the type of equipment to be used with the specific clearing task. There are many options available, including excavator-mounted hydraulic grabs etc.</li> <li>• Recycle cleared vegetation for re-use on or off site. Recycling techniques include mulching, tub-grinding, wood chipping</li> </ul>

	<p>and salvage. Do not recycle weed materials as this has potential to spread weed propagules.</p> <ul style="list-style-type: none"> <li>• Obtain advice from a qualified arborist when work is proposed within the tree protection zone.</li> <li>• Clear vegetation sequentially to allow for natural retreat of fauna.</li> <li>• Employ a suitably qualified fauna spotter and a fauna catcher during the vegetation clearing and disposal phase of the project.</li> </ul>
<p><b>D. Rehabilitation and maintenance</b></p>	
<ul style="list-style-type: none"> <li>• To restore and enhance areas in the post- construction phase.</li> <li>• To maximise survival opportunities for areas of retained vegetation and newly rehabilitated areas.</li> </ul>	<ul style="list-style-type: none"> <li>• Use species native to the site, including species known to provide food and habitat for native fauna or those species identified in SC6.4.5 (Planting species list).</li> <li>• Use a mix of species which replicate all strata in the nominated Regional Ecosystem that was originally on site pre-clearing.</li> <li>• Use species to augment the functioning of ecological corridors and nodes through the site.</li> <li>• Do not use plants that will compete with or displace existing local native species, or that have the potential to become new and emerging weed species.</li> <li>• Specify a maintenance program in the Vegetation management plan to ensure the long-term health and vigour of retained vegetation and healthy growth of new plantings, including specified growth targets. Give details on mulching, watering and fertiliser regimes, regular inspection schedules for damage or disease, replacement planting criteria and weed control measures.</li> </ul>

## **SC6.3 Heritage planning scheme policy**

### **SC6.3.1 Introduction**

#### **SC6.3.1.1 Relationship to the Planning Scheme**

- (1) This planning scheme policy provides:
  - (a) information the Council may request for a development application; and
  - (b) guidance or advice about satisfying an assessment benchmarks which identifies this planning scheme policy as providing that guidance or advice.

Note – This planning scheme policy does not remove obligations under the *Queensland Heritage Act 1992* for places identified on the Queensland Heritage Register.

#### **SC6.3.1.2 Purpose**

- (1) The purpose of this planning scheme policy is to provide information, guidance and advice for satisfying the assessment benchmarks for the preparation of a site specific:
  - (a) Heritage impact assessment report;
  - (b) Heritage management plan; and
  - (c) Archaeological management plan.

#### **SC6.3.1.3 Heritage overlay mapping**

- (1) Heritage overlay mapping has been prepared for the local government area, showing the areas of local and state heritage significance. This mapping has been prepared in accordance with the requirements of the SPP. The specific overlay to which this PSP applies is:
  - (i) Heritage overlay code. Mapping identifies the Commonwealth, State heritage place and Local heritage place features.

## SC6.3.2 Requirements of heritage documentation

- (1) Heritage documentation to be prepared in a clear and concise manner, consistent with the elements identified in Table SC 6.3.2.1 (Requirements of heritage documentation) below, as well as any specific requirements identified in the relevant sub-sections of this report.

**Table SC 6.3.2.1 Requirements of heritage documentation**

Documentation	Preparation	Report requirements
Heritage impact assessment report	<ul style="list-style-type: none"> <li>Prepared by a suitably qualified professional with tertiary qualification in an area related to heritage conservation and appropriate technical expertise in the field of cultural heritage identification and mitigation.</li> <li>Consultation with other entities may also be necessary including Council, State government and other relevant agencies or individuals.</li> </ul>	<ul style="list-style-type: none"> <li>A site specific Heritage impact assessment report may be requested to provide additional information to Council.</li> <li>A site specific Heritage impact assessment report is to be prepared in accordance with:               <ol style="list-style-type: none"> <li>SC6.3.3 (Heritage impact assessment report);</li> <li>the Burra Charter: The Australian ICOMOS Charter for places of cultural heritage significance (2013); and</li> <li>the <i>Aboriginal Cultural Heritage Act 2003</i>.</li> </ol> </li> <li>All investigations, testing and design should be undertaken in accordance with industry practice and the provisions of relevant Australian Standards.</li> </ul>
Heritage management plan	<ul style="list-style-type: none"> <li>Prepared by a suitably qualified professional with tertiary qualification in an area related to heritage conservation and appropriate technical expertise in the field of cultural heritage identification and mitigation.</li> <li>Consultation with other entities may also be necessary including Council, State government and other relevant agencies or individuals.</li> </ul>	<ul style="list-style-type: none"> <li>A site specific Heritage management plan may be requested to provide additional information to Council.</li> <li>A site specific Heritage management plan is to be prepared in accordance with:               <ol style="list-style-type: none"> <li>SC6.3.4 (Heritage management plan);</li> <li>the Burra Charter: The Australian ICOMOS Charter for places of cultural heritage significance (2013); and</li> <li>the <i>Aboriginal Cultural Heritage Act 2003</i>.</li> </ol> </li> <li>All investigations, testing and design should be undertaken in accordance with industry practice and the provisions of relevant Australian Standards.</li> </ul>
Archaeological management plan	<ul style="list-style-type: none"> <li>Prepared by a suitably qualified professional with tertiary qualification in archaeology and appropriate technical expertise in the surveying, identification, recording, assessment and</li> </ul>	<ul style="list-style-type: none"> <li>A site specific Archaeological management plan may be requested to provide additional information to Council.</li> <li>A site specific Archaeological management plan is to be prepared in accordance with:</li> </ul>

	<p>evaluation archaeological sites.</p> <ul style="list-style-type: none"> <li>• Consultation with other entities may also be necessary including Council, State government and other relevant agencies or individuals.</li> </ul>	<ul style="list-style-type: none"> <li>c) SC6.3.5 (Archaeological management plan);</li> <li>d) Guideline: Archaeological investigations, DES, 2019.</li> <li>e) the Burra Charter: The Australian ICOMOS Charter for places of cultural heritage significance (2013); and</li> <li>f) the <i>Aboriginal Cultural Heritage Act 2003</i>.</li> </ul> <ul style="list-style-type: none"> <li>• All investigations, testing and design should be undertaken in accordance with industry practice and the provisions of relevant Australian Standards.</li> </ul>
--	--	---

### **SC6.3.3 Heritage impact assessment report**

#### **SC6.3.3.1 Purpose of a Heritage impact assessment report**

- (1) A Heritage impact assessment report is required to:
  - (a) quantify the extent and severity of potential damage to or impacts on a Heritage place; and
  - (b) provide information and guidance to support the outcomes required by the Heritage overlay code.

#### **SC6.3.3.2 Preparation of a Heritage impact assessment report**

- (1) A Heritage impact assessment report is to include at a minimum:
  - (a) a description of the history of the place and a description of the place (including any relevant components, contents, spaces and views that contribute to the significance of the place noted in the Place Card);
  - (b) a review of the Statement of Significance of the place;
  - (c) reference to an existing Conservation management plan or Archaeological management plan and the management policies included in either plan (if available);
  - (d) plans that illustrate the development plan and site layout, in relation to the heritage register boundary, cadastral boundary and significant heritage fabric described in the Local heritage placecard, and
    - i. if involving alterations - sufficient plans to show how a design response seeks to avoid, minimise and mitigate impacts on cultural heritage significance (such as a site plan, floor plans, elevations, sections, plan projections, elevations, architectural drawings, artist's representations, imagery and 3D representations); or
    - ii. if involving partial demolition – sufficient plans to show the extent of demolition of the Local Heritage Place.
  - (e) a heritage impact statement (based on the principles of the Burra Charter: The Australian ICOMOS Charter for places of cultural heritage significance), including:
    - (i) photographs of the Heritage place;
    - (ii) the identification of the aesthetic, architectural, historical, scientific and social or technological significance; and
    - (iii) the demonstration that proposed development conserves, or minimises the impact on, the significance of the place and, if relevant, reflects the management policies contained in the Conservation management plan or Archaeological management plan;
  - (f) if it is determined that the proposed development will impact the significance of the place, information must be provided to demonstrate why the change is required, what options were considered and what measures are provided to reduce the detrimental impact that may result from the change; and
  - (g) list any references used in the production of the statement and any relevant technical information or correspondence from government departments.

## **SC6.3.4 Heritage management plan**

### **SC6.3.4.1 Purpose of a Heritage management plan**

- (1) A Heritage management plan is required to:
  - (a) identify the strategies and management techniques a development is to implement to mitigate or reduce adverse impacts on a Heritage place as a result of development; and
  - (b) provide information and guidance to support the outcomes required by the Heritage overlay code.

### **SC6.3.4.2 Preparation of a Heritage management plan**

- (1) A Heritage management plan is to include at a minimum:
  - (a) an outline of the significance of the place, the conditions of approval for development to a Heritage place and particular requirements to manage the significance of the place during development, including, as required by Council, an archival recording of the place where demolition or removal is required;
  - (b) a description of the extent of the heritage boundary and the specific heritage features within the boundary;
  - (c) an outline of the requirements for the management of any approved works within sensitive areas, including:
    - (i) council conditions of approval for the work;
    - (ii) work method statements for work requiring particular care and attention to appropriate conservation methods; and
    - (iii) training of contractors, including ‘tool box talks’;
  - (d) an assessment of the risk inherent in particular activities to the significance of the place and appropriate mitigation and/or monitoring responses; and
  - (e) a procedure for the incidental discovery of items of potential cultural heritage significance, including archaeological artefacts.

### **SC6.3.5 Archaeological management plan**

#### **SC6.3.5.1 Purpose of an Archaeological management plan**

- (1) An Archaeological management plan is required to:
  - (a) provide additional information regarding the extent and severity of ground-breaking activities on a site;
  - (b) identify the management activities which will be undertaken to reduce adverse impacts as a result of development that has been identified as an archaeological place; and
  - (c) provide information and guidance to support the outcomes required by the Heritage overlay code.

#### **SC6.3.5.2 Preparation of an Archaeological management plan**

- (1) An Archaeological management plan is to be prepared in accordance with Table SC6.3.2 (Requirements of heritage documentation) and include at a minimum:
  - (a) descriptions of the significant archaeological features and artefacts of a place, or the potential for archaeological features and artefacts to be present, and the proposed methodology to manage impacts on the features and artefacts during approved ground-breaking activity, including the procedure to manage unexpected discoveries;
  - (b) outline of the methodology for evaluating the extent, nature and integrity of the site and its significance should ground breaking activities be unavoidable;
  - (c) definitions of the appropriate management measures for the site, having regard to its potential significance, inclusive of the establishment of any ground disturbance exclusion zones and/or monitoring areas;
  - (d) specification of the process for dealing with new/unexpected finds of an archaeological nature resulting from ground-breaking activities must be in accordance with the *QLD Heritage Act 1992*, including advising the appropriate authority in accordance with s89 of the *QLD Heritage Act 1992*, and also Council of any such discovery; and
  - (e) an outline of the process for the curation and long-term ownership and management of any archaeological material collected as a result of development activities within the curtilage of a Heritage place that has been identified as an archaeological place.

## **SC6.4 Landscaping planning scheme policy**

### **SC6.4.1 Introduction**

#### **SC6.4.1.3 Relationship to the Planning Scheme**

- (1) This planning scheme policy provides:
  - (a) information the Council may request for a development application; and
  - (b) guidance or advice about satisfying an assessment benchmarks which identifies this planning scheme policy as providing that guidance or advice.

#### **SC6.4.1.4 Purpose**

- (1) The purpose of this planning scheme policy is to provide information, guidance and advice for satisfying the assessment benchmarks for the preparation of a site specific:
  - (a) Landscaping plan;
  - (b) Landscaped separation buffer plan; and
  - (c) Planting species list.

## SC6.4.2 Requirements of landscaping documentation

- (1) Landscaping documentation to be prepared in a clear and concise manner, consistent with the elements identified in Table SC 6.4.2.1 (Requirements of landscaping documentation) below, as well as any specific requirements identified in the relevant sub-sections of this report.

**Table SC 6.4.2.1 Requirements of landscaping documentation**

Documentation	Preparation	Report requirements
Landscaping plan	<ul style="list-style-type: none"> <li>Prepared by a suitably qualified professional with appropriate technical expertise in landscape architecture, horticulture or similar</li> <li>Consultation with other entities may also be necessary including Council, State government and other relevant agencies or individuals.</li> </ul>	<ul style="list-style-type: none"> <li>A site specific Landscaping plan may be requested to provide additional information to Council.</li> <li>A site specific Landscaping plan is to be prepared in accordance with                             <ol style="list-style-type: none"> <li>SC6.4.3 (Landscaping plan);</li> <li>SC6.4.5 (Planting species list); and</li> <li>SC6.8 (WRC development manual).</li> </ol> </li> </ul>
Landscaped separation buffer plan	<ul style="list-style-type: none"> <li>Prepared by a suitably qualified professional with appropriate technical expertise in the identification and mitigation of agricultural or industrial impacts or the design of landscaped buffers.</li> <li>Consultation with other entities may also be necessary including Council, State government and other relevant agencies or individuals.</li> </ul>	<ul style="list-style-type: none"> <li>A site specific landscaped separation buffer plan may be requested to provide additional information to Council.</li> <li>A site specific Landscaped separation buffer plan is to be prepared in accordance with                             <ol style="list-style-type: none"> <li>SC6.4.4 (Landscaped separation buffer plan);</li> <li>SC6.4.5 (Planting species list); and</li> <li>SC6.8 (WRC development manual).</li> </ol> </li> </ul>
Planting species list	-	-

### **SC6.4.3 Landscaping plan**

#### **SC6.4.3.1 Purpose of a Landscaping plan**

- (1) A landscaping plan is required to:
  - (a) identify the suitable purposes and specifies plants recommended to be established on the site; and
  - (b) ensure appropriate methods and management activities are implemented to ensure survival of vegetation; and
  - (c) provide information and guidance to support the outcomes required by the Landscaping code.

#### **SC6.4.3.2 Preparation of a Landscaping plan**

- (1) A Landscaping plan is to include a plan of layout and supporting text.
- (2) A description and dimensioned site plan (drawn to an appropriate metric scale) is to include at a minimum:
  - (a) the project description and location;
  - (b) landscape architect / designer's name and contact details;
  - (c) the date on which the plan was prepared together with a plan number which clearly identifies the plan and any amendments thereof;
  - (d) the location of property boundaries, road alignments and street names;
  - (e) the location of underground and overhead services, including drainage, sewerage, power lines, electricity, telephone and gas;
  - (f) the location, botanical name and size of existing trees and shrubs and intended retention or removal of these plants to be clearly nominated;
  - (g) contours and spot levels, both existing and proposed to all surfaces, including levels at the base of all existing vegetation to be retained, and surface levels of paved areas and access covers;
  - (h) location and design of proposed stormwater drainage works including direction of overland flow, location of field inlets (as required) and methods to ensure erosion control;
  - (i) details of the location of any earth cuts, fills or mounds within landscaped areas and details of proposed measures to ensure stability, including location, height and materials of retaining walls;
  - (j) location of all existing and proposed buildings, landscape structures, storage areas, pathways, driveways and parking areas, outdoor furniture (where relevant e.g. centres) and fencing;
  - (k) details including design, materials used and colours of proposed edging, surface treatments, fencing, pergolas and raised gardens;
  - (l) location and nature of all proposed vegetation including:
    - (i) a graphic code/key (as nominated on the plan);
    - (ii) scientific or botanical names of plants;

- (iii) common names of plants (not essential);
  - (iv) spread at maturity;
  - (v) height at time of planting (measured from pot soil level to top of growing tip) (not essential);
  - (vi) crown width at time of planting (not essential); and
  - (vii) quantity of each species used;
- (m) evidence of measures taken for conservation, protection and maintenance of sites which have environmental, ecological, cultural, architectural, historic, scenic, visual, streetscape or scientific significance; and
- (n) a maintenance plan, detailing the intended arrangements for maintenance of the landscaping, and the conservation, protection and maintenance of significant sites, including at a minimum, the schedule for:
  - (i) weed control;
  - (ii) irrigation and watering;
  - (iii) plant maintenance and pruning; and
  - (iv) fertilizer management.

## **SC6.4.4 Landscaped separation buffer plan**

### **SC6.4.4.1 Purpose of a Landscaped separation buffer plan**

- (1) A landscaped buffer plan is required to:
  - (a) achieve appropriate separation between:
    - (i) sensitive land uses and Rural, Special industry or High impact industry zones; or
    - (ii) major infrastructure elements (such as State-controlled roads) and sensitive uses; or
    - (iii) environmentally significant areas or edges of existing Native vegetation from development;
  - (b) ensure appropriate mitigation methods and management activities are implemented to reduce the potential conflict between incompatible uses; and
  - (c) provide information and guidance to support the outcomes required by the Landscaping code, Reconfiguring a lot code and the Agricultural land overlay code.

### **SC6.4.4.2 Preparation of a Landscaped separation buffer plan**

- (1) A Landscaped separation buffer plan is to include a plan of the layout and supporting text.
- (2) A description and dimensioned site plan (drawn to an appropriate metric scale) is to include at a minimum:
  - (a) the project description and location;
  - (b) landscape architect / designer's name and contact details;
  - (c) the date on which the plan was prepared together with a plan number which clearly identifies the plan and any amendments thereof;
  - (d) the location of property boundaries, road alignments and street names;
  - (e) consideration and descriptions of the existence and location of surrounding land uses. The development should be in a position which will not result in the potential for land use conflict between neighbouring land uses;
  - (f) consideration of the nature of the buffer. Buffer areas may be temporary and can be reserved for public open spaces or further residential development once conflicting land use has ceased. Residential subdivision applications may contain mandatory identified buffer areas for development unless the development occurs after neighbouring agricultural activities have ceased;
  - (g) the extent of the buffer area, the location and spacing of the trees and shrubs with the provision of a list of tree and shrub species, having regard to the type of buffer required.
- (10) Separation buffers are to be provided between sensitive uses or any part of a lot included in a Residential zone, Emerging community zone or Rural residential zone and Rural or Industry zones. This buffer may be provided in the form of a landscaped separation buffer (distances set out in Table SC 6.4.4.2.1) or as an open space separation buffer (distances set out in Table SC 6.4.4.2.2).

- (a) To be effective, a landscaped separation buffer is to meet the following criteria:
- (i) be located as close as practicable to the point of release of the spray;
  - (ii) not be located on land used for a Rural activity;
  - (iii) provide a minimum landscaped separation distance in accordance with the dimensions of Table SC 6.4.4.2.1 (Landscaped separation buffer distances).

**Table SC 6.4.4.2.1 Landscaped separation buffer distances**

Zone/Existing Use	Total landscaped separation buffer distance (including fire break)
Rural zone	40m
Low impact industry zone	
Medium impact industry zone	
Waterfront and marine industry zone	
Low impact industry use	
Marine industry use	
Medium impact industry use	
Research and technology industry use	
Service industry use	
Warehouse use	
High impact industry zone	50m
High impact industry use	
Special impact zone	60m
Special industry use	

- (iv) provide a 10m cleared fire break area on either side of a vegetated strip (this fire break area is included within the total width of the landscaped separation buffer. Where the total width of landscaped separation buffer is 40m, 10m cleared area is located either side of a 20m wide vegetated area).
- (v) the vegetated area is to be comprised of a minimum of three rows ensuring there is foliage from base to crown with no gaps in the lower canopy:
  - (A) rows 1 and 3 are composed of short to medium sized tree species; and
  - (B) row 2 is composed of taller tree species.
- (vi) contain random plantings of a variety (at least 3) of tree and shrub species of differing growth habits, at a spacing of 2.5m and listed in Table SC 6.4.5.2.3 (Large screening shrubs and windbreaks) of PSP SC6.4.5 (Planting species list);
- (vii) provide a permeable barrier which allows air to pass through the buffer. A porosity of 0.5 is acceptable (that is, approximately 50% of the screen should be air space);
- (viii) have a mature tree height of 1.5 times the spray release height or target vegetation height, whichever is the highest;
- (ix) have mature height and width dimensions which do not detrimentally impact upon adjacent cropped land;
- (x) be planted in accordance with PSP SC6.8 (WRC development manual);
- (xi) be contained within a legal covenant which outlines maintenance requirements; and
- (xii) will not be considered operational until the trees reach the minimum effective height to control spray drift (1.5 times the spray release height or target vegetation height, whichever is the highest). Until then the landscaped separation buffer is to be maintained in line with a scheduled maintenance plan. The maintenance plan is to include at a minimum a schedule for:

- (A) weed control;
  - (B) irrigation and watering;
  - (C) plant maintenance and pruning; and
  - (D) fertilizer management.
- (xiii) Residential areas should not be developed within 300metres of the incompatible land uses until the buffer is considered as operational;

Note –

- (1) The precise design of the buffer will depend on many different factors including the chemicals used, method of application, the site, the proposed land-uses and the adjacent or nearby land uses and characteristics including road reserves and existing vegetation; and
- (2) Natural geographical features (watercourses and ridge lines), public open spaces, road reserves etc. can be incorporated into meeting the required distances.
- (b) To be effective, an open space buffer is to meet the following criteria:
- (i) be located as close as practicable to the point of release of the spray;
  - (ii) not be located on land used for a Rural activity; and
  - (iii) provide a minimum open space separation distance in accordance with Table SC 6.4.4.2.2 (Open space separation distances).

**Table SC 6.4.4.2.2 Open space buffer distances**

Industry	Open Space
Sugarcane	300m
Small Crops	300m
Orchards	300m
Grazing	60m

- (11) Landscaped separation buffers between major infrastructure elements (such as State-controlled roads) and sensitive uses or between environmentally significant areas or edges of existing native vegetation and development are to meet the following criteria:
- (a) earth mounding is provided where necessary to achieve satisfactory attenuation, visual screening or land use separation;
  - (b) selected plant species are appropriate to the location, drainage and soil type; meet the buffer's functional requirements and require minimal ongoing maintenance;
  - (c) plant selection includes a range of species in accordance with the SC6.4.5 (Planting species list) to provide variation in form, colour and texture to contribute to the natural appearance of the buffer;
  - (d) planting density results in the creation of upper, mid and understorey strata with:
    - (i) large trees planted at 6m centres;
    - (ii) small trees planted at 2m centres;
    - (iii) shrubs planted at 1m centres;
    - (iv) one plant per 1m along each row;
    - (v) each row being 3m apart;
    - (vi) a minimum of six species used in the buffer with a maximum species of 2 species of shrubs; and
    - (vii) tufting plants, vines and groundcovers are planted at 0.5m to 1m centres;
  - (e) where adjoining the edge of native vegetation or waterway understorey, shrubs and vines are used to bind appropriately the buffer edges against degradation and weed infestation; and

- (f) is maintained in line with a scheduled maintenance plan until reaching its growth maturity. The maintenance plan is to include at a minimum a schedule for:
  - (i) weed control;
  - (ii) irrigation and watering;
  - (iii) plant maintenance and pruning; and
  - (iv) fertilizer management.

## SC6.4.5 Planting species list

### SC6.4.5.1 Purpose of the planting species list

- (1) The purpose of this planting species list is to:
- (a) identify suitable species of plants for establishing within the region; and
  - (b) identify suitable purposes for the species of plants recommended.

### SC6.4.5.2 Planting species list

- (1) It should be noted that plants have been categorised according to their most likely purpose, but some will be multipurpose, for example most street trees can also be used in parks, and some of the smaller, compact street or park trees will also be useful screening plants.
- (2) The Planting species list contains the following recommended species:

**Table SC 6.4.5.2.1 Verge/street trees plant list**

Species	Common name	Wet/Dry	Height (m)	Locally Available
<i>Acacia leptostachya</i>	Townsville Wattle	D	2-5	
<i>Acacia oraria</i>	Coastal Wattle	W/D	5-10	Y
<i>Acmena smithii</i>	Lilly pilly	W	5-10	
<i>Alphitonia excelsa</i>	Red Ash	W	8-10	Y
<i>Brachychiton acerifolius</i>	Flame tree	W	10-15	Y
<i>Brachychiton australis</i>	Broad-leaved Bottle Tree	D	6-10	
<i>Callistemon viminalis</i>	Weeping Bottlebrush	W/D	8-18	Y
<i>Cassia brewsteri</i> syn <i>Senna brewsteri</i>	Leichardt Bean	W/D	2-8	
<i>Cassia tomentella</i>	Velvet Bean tree	W/D	6-12	Y
<i>Chionanthus ramiflora</i>	Native Olive	W	3-5	Y
<i>Cupaniopsis anacardioides</i>	Tuckeroo	W/D	15-25	Y
<i>Cupaniopsis wadsworthii</i>	Cut leaf tuckeroo	W	3-5	Y
<i>Diploglottis obovata</i>	Blunt Leaved Tamarind	W	5-10	Y
<i>Evodiella muelleri</i>	Little pink evodia	W	5-10	Y
<i>Gossia bidwillii</i>	Python wood	W	5-10	
<i>Grevillea baileyana</i>	Scrub Beefwood	W/D	10-15	
<i>Harpulia hillii</i>	Tulipwood	W	10-20	Y
<i>Harpulia pendula</i>	Tulip wood	W	10-20	Y
<i>Hymnosporum flavum</i>	Native frangipani	W	5-12	
<i>Larsenaikia jardinei</i>	Shiny Leaved Larsenaikia	W/D	10-15	Y
<i>Lysiphyllum hookeri</i>	White Bauhinia	D	4-8	
<i>Petalostigma pubescens</i>	Quinine Berry	D	5-10	
<i>Pittosporum ferrugineum</i>	Rusty Pittosporum	W	8-10	Y
<i>Planchonia careya</i>	Cocky apple	W/D	8-15	Y
<i>Randia fitzlanni</i>	Native Gardenia	W/D	5-10	Y
<i>Syzigium australe</i>	Lilly pilly	W	5-12	Y
<i>Syzigium luehmanni</i>	Lilly pilly	W	5-12	
<i>Syzigium paniculatum</i>	Magenta Lilly Pilly	W	10-15	
<i>Xanthostemon chrysanthus</i>	Golden penda	W	8-20	Y

**Table SC 6.4.5.2.2 Large and/or park trees plant list**

Species	Common name	Wet/Dry	Height (m)	Locally Available
<i>Alphitonia petriei</i>	Pink Ash	W	10-25	Y
<i>Auranticarpa rhombifolia</i>	Diamond Leaf Pittosporum	W	20-25	
<i>Arytera divaricata</i>	Gap Axe	W	30-35	
<i>Alstonia scholaris</i>	Milky pine	W	15-30	Y
<i>Agathis robusta</i>	Qld Kauri	W	20+	
<i>Araucaria cunninghamii</i>	Hoop pine	W/D	20-30	
<i>Backhousia citriodora</i>	Lemon Ironwood	W	5-10	Y
<i>Brachychiton acerifolius</i>	Flame tree	W/D	10-15	Y
<i>Brachychiton compactus</i>	Whitsunday bottle tree	W/D	10-20	Y
<i>Cassia brewsteri</i>	Brewsters Cassia	W/D	6-12	
<i>Cassia tomentella</i>	Velvet Bean tree	W	6-12	Y
<i>Casuarina cunninghamiana</i>	River She-oak	W/D	10-30	Y
<i>Cordia subcordata</i>	Orange cordia	W	8-15	
<i>Corymbia tessellaris</i>	Moreton Bay Ash	W/D	10-30	Y
<i>Cupaniopsis anacardioides</i>	Tuckeroo	W/D	15-25	Y
<i>Commersonia bartramia</i>	Brown Kurrajong	W	12-20	
<i>Elaeocarpus grandis</i>	Blue Quandong	W	20-30	Y
<i>Elaeocarpus obovatus</i>	Hard Quandong	W	30-40	
<i>Eucalyptus raveretianna</i>	River Black Butt, Black Ironbox	W/D	18-25	Y
<i>Eucalyptus tereticornis</i>	Blue Gum, Forest Red Gum	W/D	20-30	Y
<i>Euroschinus falcata</i>	Ribbonwood, Pink Poplar	W/D	20-30	Y
<i>Flindersia australis</i>	Crows Ash	W	15-25	Y
<i>Flindersia schottiana</i>	Bumpy Ash	W	25-40	Y
<i>Harpulia hillii</i>	Tulipwood	W	10-20	Y
<i>Harpulia pendula</i>	Tulip wood	W	10-20	Y
<i>Jagera pseudorhus</i>	Pink tamarind, Foambark	W	6-10	Y
<i>Lophostemon confertus</i>	Brush box	W	20-30	Y
<i>Mallotus philippensis</i>	Red Kamala	W	10-20	Y
<i>Melaleuca dealbata</i>	Blue tea tree	W	12-25	Y
<i>Melaleuca leucadendra</i>	Weeping paperbark	W/D	20-30	Y
<i>Melaleuca quinquenervia</i>	Broad-leaved Paperbark	D	15-20	
<i>Millettia pinnata</i>	Pongamia	W/D	8-20	Y
<i>Melicope elleryana</i>	Pink Euodia	W	15-30	Y
<i>Mimusops elengi</i>	Spanish cherry	W/D	15-18	Y
<i>Nauclea orientalis</i>	Leichardt tree	W	20-30	Y
<i>Paraserianthes toona</i>	Mackay Cedar	W/D	20-30	Y
<i>Pleiogynium timorense</i>	Burdekin plum	W/D	10-20	Y
<i>Syzigium australe</i>	Lilly pilly	W	5-12	Y
<i>Terminalia porphyrocarpa</i>		D	10-15	
<i>Terminalia sericocarpa</i>	Damson	W	20-30	Y
<i>Toona australis</i>	Red Cedar	W	15-25	Y
<i>Waterhousia florabunda</i>	Weeping Lilly Pilly	W/D	20-30	Y
<i>Xanthostemon chrysanthus</i>	Golden penda	W	8-20	Y

**Table SC 6.4.5.2.3 Large screening shrubs and windbreaks plant list**

Species	Common name	Wet/Dry	Height (m)	Locally Available
<i>Acacia decora</i>		W/D	2-5	
<i>Acacia flavescens</i>	Yellow wattle	W/D	4-10	Y
<i>Acacia holosericea</i>	Soapbush Wattle	D	4-5	Y
<i>Acacia leptocarpa</i>		D	6-10	Y
<i>Acacia leptostachya</i>	Townsville wattle	D	2-5	Y
<i>Callistemon spp.</i>	Bottlebrush	W/D	5-12	Y
<i>Cassia brewsteri</i>	Brewsters Cassia	W/D	6-12	
<i>Cassia brewsteri syn Senna brewsteri</i>	Leichardt Bean	W/D	1-8	
<i>Cassia tomentella</i>	Velvet Bean tree	W	6-12	
<i>Clerodendrum floribundum</i>	Lolly Bush	W/D	3-5	
<i>Cordia subcordata</i>	Orange cordia	W	8-15	
<i>Cupaniopsis wadsworthii</i>	Cut leaf tuckeroo	W/D	3-5	
<i>Dodonaea triquetra</i>	Large-leaved Hop Bush	W/D	3-5	
<i>Dodonaea viscosa</i>	Sticky Hop Bush	W/D	1.5-4	Y
<i>Eugenia reinwardtiana</i>	Beach Cherry	W/D	2-6	
<i>Glochidion lobocarpum</i>	Cheese Tree	W/D	1-6	Y
<i>Glochidion summatranum</i>	Umbrella Cheese Tree	W	3-8	Y
<i>Hibiscus tiliaceus</i>	Native hibiscus	W	4-10	Y
<i>Macaranga involucrata</i>	Brown Macaranga	W/D	4-10	
<i>Macaranga tanarius</i>	Macaranga	W/D	4-10	
<i>Pipturis argenteus</i>	Native mulberry	W	4-10	
<i>Syzigium australe</i>	Lilly pilly	W/D	5-12	Y

Table SC 6.4.5.2.4 Small to medium shrubs plant list

Species	Common name	Locally Available
<i>Abelia grandiflora</i> 'Dwarf'	Glossy Abelia	
<i>Acalypha</i> <i>Inferno</i>		Y
<i>Acalypha</i> <i>Firestorm</i>		Y
<i>Ardisia crenulata</i>		
<i>Baeckia</i> 'La Petite'		
<i>Baeckia virgata</i>	Twiggy Health Myrtle	
<i>Banksia robur</i>	Swamp Banksia	
<i>Banksia spinulosa</i>	Hairpin Banksia	
<i>Bauhinia galpinii</i>	Orange Bachinia	
<i>Bouganvillea-Smarty Pants</i>	Dwarf Bongonvillea	
<i>Breynia disticha</i>	Snow Bush	
<i>Bromeliad</i> Spp.		
<i>Calathea zebrina</i>	Zebra Plant - Ground cover	
<i>Calliandra tweedi</i>		
<i>Callistemon</i> 'Little John'		
<i>Callistemon</i> 'Wildfire'		
<i>Callistemon pachyphylus</i> - green		
<i>Canna Lily</i> - all varieties		
<i>Cassia odorata</i>		
<i>Codiaem</i> - all varieties	Croton	
<i>Codiaeum</i> 'Golddust'		
<i>Codiaeum</i> 'Norma'		
<i>Codiaeum</i> 'Petra'		
<i>Cordyline</i> - all varieties		
<i>Cordyline</i> 'Rubra'		
<i>Cordyline stricta</i>		
<i>Cordyline terminalis</i>		
<i>Cuphea ignea</i>	Cigar Flower	
<i>Dracaena</i> - all varieties		Y
<i>Drejerella guttata</i>	Shrimp Plant	
<i>Duranta</i> 'Aussie 2000'		Y
<i>Duranta</i> 'Sheena's Gold'		Y
<i>Duranta repens</i> 'Alba'		Y
<i>Euphorbia pulcherrima</i>	Poinsetta	
<i>Gordonia exillaris</i>		
<i>Graptophyllum excelsum</i>	Scarlet Fuchsia	
<i>Graptophyllum pictum</i>	Caricature Plant	
<i>Graptophyllum tricolor</i>		
<i>Grevillia</i> 'Superb'	Gordonia	
<i>Hakea plurinervia</i>		
<i>Hakea purpurea</i>		
<i>Heliotropium arborescens</i>	Cherry Pie	
<i>Hemerocallis littoralis</i>	Spider Lilly	
<i>Hibiscus</i> - all varieties		
<i>Hibiscus</i> spp.	Chinese Rose	
<i>Ixora</i> - 'Red Sunkist, Little Willy'		Y
<i>Ixora</i> - dwarf varieties		Y
<i>Ixora</i> 'Prince of Orange'		Y
<i>Ixora</i> 'Pygmy Pink' Twilight Glow		Y
<i>Ixora</i> 'Sunshine'		Y
<i>Justica carnea</i>	Flamingo Plant	
<i>Leea indica</i>	Hawaiian Holly	Y
<i>Leptospermum flavescens</i>		
<i>Melaleuca</i> 'Claret Tops'		Y
<i>Melaleuca thymifolia</i>	Thyme honey myrtle	
<i>Melaleuca trichoscatachya</i> 'Compacta'		

<i>Metrosideros Springfire</i>		
<i>Metrosideros Tahiti</i>		
<i>Murraya Min a Min</i>	Mini Mock Orange	Y
<i>Mussaenda sp</i>	Bankock Rose	
<i>Odontonema strictum</i>	Firespike	
<i>Pachystachys lutea</i>	Lollipop Plant or Super Goldie	
<i>Pedilanthus - 'Exotica &amp; Tricolour'</i>		
<i>Pentas lanceolata</i>	Star – cluser	
<i>Persoonia falcata</i>	Geebung	Y
<i>Philodendron 'Xanadu'</i>		
<i>Philodendron roystonii</i>		
<i>Philodendron selloum</i>	Lacy Tree Philodendron	
<i>Phyllanthus multiflorus</i>	Waterfall Plant	Y
<i>Phyllanthus cuscutiflorus</i>		Y
<i>Plumbago capensis 'Blue'</i>		
<i>Poinsettia - all varieties</i>		
<i>Polyscias sp.</i>	Aralia	Y
<i>Russellia equisetiformis</i>	Coral Plant	
<i>Scaevola taccada</i>	Sea Lettuce	Y
<i>Schefflera arboricola</i>	Dwarf Umbrella Tree	
<i>Steptosolen jamesohnii</i>	Marmalade Bush	
<i>Syzygium paniculatum - 'Dwarf'</i>		
<i>Syzygium var 'Aussie Copper'</i>		
<i>Syzygium var 'Bush Christmas'</i>		
<i>Syzygium zeherii</i>		
<i>Syzygium wilsonnii</i>	Powder Puff Lilly Pilly	
<i>Thuja orientalis</i>		
<i>Tibouchina 'Jules'</i>		
<i>Westringia fruticosa Zena</i>		Y

Table SC 6.4.5.2.5 Groundcover, borders and tufted or clumping plants plant list

Species	Common name	Locally Available
<i>Abelia grandiflora</i> 'Nana'		
<i>Adenium obesum</i>		Y
<i>Agapanthus orientalis</i> 'White' & 'Blue'		
<i>Aglaonema</i> sp	Chinese Evergreen	
<i>Ajuga reptans</i> 'Burgundy'	Wild Mint	
<i>Alpinia caerulea</i>	Native Ginger	Y
<i>Alpinia zerumpet</i>	Green Ginger	Y
<i>Ardisia crenata</i>	Spice berry	
<i>Aspidistra elatior</i>	Cast Iron Plant	
<i>Babingtonia tozerensis</i>		
<i>Babingtonia bidwillii</i>	Howies Sweet Midget	
<i>Baeckia virgata</i> 'Mt Tozer'		
<i>Baeckia virgata</i> 'Sweet Midget'		
<i>Baeckia virgata</i> dwarf		
<i>Beaucarnia recurvata</i>	Ponytail palm	Y
<i>Brachycome</i> spp	Rock Daisy	
<i>Chlorophytum</i> spp.	Spider Plant	Y
<i>Clivia miniata</i> 'Belgian Hybrid'	Kaffir Lilly	
<i>Cordyline australis</i>		
<i>Crinum pedunculatum</i>	Native Spider Lilly	Y
<i>Cuphea</i> 'Madhatter'	False heather	Y
<i>Cuphea</i> 'Mexican Heath'		Y
<i>Dampiera diversifolia</i>		
<i>Dianella Border Silver</i>		Y
<i>Dianella caerulea</i>	Paroo Lilly	Y
<i>Dieffenbachia maculata</i>	Dumb Cane	
<i>Dietes bicolor</i>	Flax Lilly	Y
<i>Dietes grandiflora</i>	Fortnight Lilly	
<i>Erigeron karvinskianus</i>	Seaside Daisy	
<i>Eustrephus latifolius</i>	Wombat Berry	Y
<i>Evolvulus</i> 'Blue Sapphire'	Wild Ins	Y
Ferns - all varieties		
<i>Furcraea foetida varigata</i>	Hemp Plant	Y
<i>Gardenia</i> 'Radicans'	Minature Gardenia	Y
<i>Gazania</i> - perennial varieties		
<i>Gazania</i> 'Sunshine'		
<i>Gloriosa superba</i>	Glowy Lily	
<i>Grevillea</i> 'Bronze Rambler'		
<i>Grevillea</i> 'Fanfare'		
<i>Grevillea biternata</i>		
<i>Heliconia psittacorum</i>	'Parrot Flower'	
<i>Heliconia</i> spp		
<i>Hemerocallis</i>	Day Lilies	
<i>Hemigraphis alternata</i>	Purple Wattle Plant	Y
<i>Heterocentron elegans</i>	Lascondra 'Peal Flower'	
<i>Hibertia scandens</i>		Y
<i>Hippeastrum</i> sp		
<i>Hymenocallis</i>	Thai Spider lilly	Y
<i>Liriope evergreen giant</i>		Y
<i>Liriope Stripey White</i>		Y
<i>Lomandra hystrix</i>	Mat-rush	Y
<i>Lomandra longifolia</i>	Mat Rush	
<i>Lonicera nitida</i>	Box Honeysuckle	
<i>Medinilla magnifica</i>		Y
<i>Medinilla Pixie Pink</i>		Y
<i>Ophiopogon japonicus</i>	Mondo Grass	Y

<i>Philodendron xanadu</i>		Y
<i>Scaevola 'Purple Fanfare'</i>		
<i>Sedum spp.</i>		Y
<i>Spathiphyllum</i>	Madonna Lily	Y
<i>Spathiphyllum 'La Petite'</i>	Peace Lilly	Y
<i>Strelitzia reginae</i>	Bird of Paradise	Y
<i>Strelitzia nicholai</i>		Y
<i>Tropaeolum sp</i>	Nasturtium	
<i>Verberba xhlybrida</i>	Gloria Lily	
<i>Viola hedracea</i>	Native Violet	
<i>Xanthorrhoea australis</i>	Grasstree	
<i>Xanthorrhoea fulva</i>	Grasstree	
<i>Xerochrysum bracteatum</i>	Everlasting Paper Daisy	Y
<i>Zamioculcas zammifolia</i>	Zanzibar Gem	Y
<i>Zoyzia</i>	No Mow Grass	Y

**Table SC 6.4.5.2.6 Palms, ferns and cycads plant list**

Species	Common name	Locally Available
<i>Archontophoenix alexandrae</i>	Alexander Palm	Y
<i>Archontophoenix cunninghamiana</i>	Bangalow Palm	
<i>Asplenium Nidus</i>	Bird Nest Fern - Shade	
<i>Bismarckia nobilis</i>	Bismarck Palm	
<i>Carpentaria acuminata</i>	Carpentaria Palm	
<i>Chamaedorea atrovirens</i>	Cascade Palm	
<i>Chamaedorea metalica</i>		
<i>Chamaedorea safrizii</i>	Bamboo Palm	
<i>Chrysalidocarpus cabadae</i>		
<i>Chrysalidocarpus lucubensis</i>	Madagascar Palm	
<i>Chrysalidocarpus lutescens</i>	Golden Cane Palm	
<i>Cyathea cooperii</i>	Tree Fern	
<i>Cycas revoluta</i>	Sago Palm	
<i>Cyrtostachys renda</i>	Sealing Wax	
<i>Dictyosperma album</i>	Princess Palm Red Hurricane Palm	
<i>Elaeis guineensis</i>	African Oil	
<i>Howea forsteriana</i>	Kenna Palm	
<i>Hyophorbe lagenicaulis</i>	Bottle Palm	
<i>Hyophorbe verschaffeltii</i>	Spindle Palm	
<i>Laccospadix australasica</i>	Atherton Palm	
<i>Licuala grandis</i>	Fan	
<i>Licuala ramsayi</i>		
<i>Livistona australis</i>	Cabbage Palm	
<i>Livistona chinensis</i>	Chinese Fan palm	
<i>Livistona decora</i>	Weeping Cabbage Palm	Y
<i>Macrozamia miquellii</i>		
<i>Macrozamia moorei</i>	Cycad	
<i>Neodypsis decaryi</i>	Triangle Palm	
<i>Normanbya normanbyi</i>	Black Palm	
<i>Pandanus pedunculatus</i>	Screw Pine	
<i>Phoenix canariensis</i>	Canary Island Date	
<i>Pritchardia pacifica</i>	Fijian Fan Palm	
<i>Ptychosperma elegans</i>	Solitaire Palm	
<i>Ptychosperma macarthurii</i>	Macarthur Palm	
<i>Ravenea rivularis</i>	Majestic Palm	
<i>Rhapis excelsa</i>	Lady Palm	
<i>Rhapis hunillii</i>	Dwarf Lady cluster	
<i>Roystonea oleracea</i>	Caribbean Royal	
<i>Roystonea regia</i>	Cuban Royal	
<i>Sabal palmetto</i>	Palme Ho Palm	
<i>Veitchia joannis</i>	Handsome solitary feather palm	
<i>Veitchia mernillii</i>	Christmas Palm	
<i>Washingtonia robusta</i>	Cotton Palm	
<i>Wodyetia bifurcata</i>	Foxtail Palm	
<i>Zamia furfuracea</i>	Jamaica sagotree cardboard cycad	
<i>Zamia furfuracea</i>	Cardboard Cycad	

Table SC 6.4.5.2.7 Climbers and creepers plant list

Species	Common name	Locally Available
<i>Aristolochia acuminata</i>	Native Dutchman's Pipe	Y
<i>Clamatis Vitalba</i>	Old Man's Beard	
<i>Cougea tomenhosa</i>	Shower orchid	

Species	Common name	Locally Available
<i>Ficus pumila</i>	Climbing Fig	
<i>Hardenbergia violacea</i>	Sarsparilla vine	
<i>Hibbertia scandens</i>	Twining guinea flower	
<i>Hoya carnosa</i>	Wax Plant	
<i>Jasminum aemulum</i>		
<i>Jasminum didymum</i>	Coastal Jasmine	Y
<i>Jasminum sambac</i>	Grand Duke of Tuscany	
<i>Lonicera – multiflora</i>	Honeysuckle	
<i>Lonicera heckrottii</i>	Honeysuckle	
<i>Lonicera japonica</i>	Japanese Honeysuckle	
<i>Mandevilla x amabilis</i>	Dipladenia	
<i>Milletia megasperma</i>	Native Wisteria	
<i>Mucuma Bennettii</i>	New Guinea Creeper	
<i>Pandorea jasminoides</i>	Bower of Beauty	
<i>Pandorea pandorana</i>	Wonga-Wonga Vine	Y
<i>Passiflora coccinea</i>	Red Passion Flower	
<i>Passiflora edulis</i>	Passionfruit	
<i>Quisqualis indica</i>	Rangoon Creeper	
<i>Solanum jasminoides</i>	Jasmine Nightshade	
<i>Stephanotis floribunda</i>	Clustered Wax Flower	
<i>Strongylodon macrobotrys</i>	Jade Vine	
<i>Trachelospermum jasminoides</i>	Star Jasmine	
<i>Vitex rotundifolia</i>	Creeping vitex	Y

## **SC6.5 Natural hazards planning scheme policy**

### **SC6.5.1 Introduction**

#### **SC6.5.1.1 Relationship to the Planning Scheme**

- (1) This planning scheme policy provides:
  - (a) information the Council may request for a development application; and
  - (b) guidance or advice about satisfying an assessment benchmarks.

#### **SC6.5.1.2 Purpose**

- (1) The purpose of this planning scheme policy is to provide information, guidance and advice for satisfying the assessment benchmarks for the preparation of a site specific:
  - (a) Coastal hazard assessment report;
  - (b) Flood hazard assessment report;
  - (c) Landslide hazard (geotechnical) assessment report.

#### **SC6.5.1.3 Hazard overlay mapping**

- (1) Natural hazard mapping has been prepared for the local government area, showing the areas natural hazard susceptibility. This mapping has been prepared in accordance with the requirements of the SPP. The specific hazard overlays to which this PSP applies are:
  - (a) Coastal environment overlay code. Mapping:
    - (i) identifies Maritime development areas, High hazard and Medium hazard sub-categories for storm tide inundation, Coastal erosion and Permanent inundation due to sea level rise at 2100 sub-category;
    - (ii) is not a substitute for a site based assessment. A site specific Coastal hazard assessment should be undertaken to verify, specific to the site, the coastal hazard risk (unless provided by council) and appropriate mitigation responses to this;
  - (b) Flood hazard overlay code. Mapping:
    - (i) identifies predicted 1% AEP flood extent at 2100 and Flood hazard area;
    - (ii) is not a substitute for a site based assessment. A site specific flood hazard assessment should be undertaken to verify, specific to the site, the flood hazard risk (unless provided by council) and appropriate mitigation responses to this;
  - (c) Landslide hazard overlay code. Mapping:
    - (i) identifies slope of 15% or greater; and
    - (ii) is not a substitute for a site based assessment. A site specific geotechnical assessment report should be undertake to verify, specific to the site, the landslide risk and appropriate mitigation responses to this.

## SC6.5.2 Requirements of natural hazard documentation

- (1) Natural hazard documentation is to be prepared in a clear and concise manner, consistent with the elements identified in Table SC 6.5.2.1 (Requirements of natural hazard documentation) below, as well as any specific requirements identified in the relevant sub-sections of this report.

**Table SC 6.5.2.1 Requirements of natural hazard documentation**

Documentation	Preparation	Report requirements
Coastal hazard assessment report	<ul style="list-style-type: none"> <li>Prepared by a Registered Professional Engineer Queensland or equivalent with experience in coastal or flood management.</li> <li>Consultation with other entities may also be necessary including Council, State government and other relevant agencies or individuals (e.g. Utility providers).</li> </ul>	<ul style="list-style-type: none"> <li>A site specific Coastal hazard assessment report may be requested to provide additional information to Council.</li> <li>A site specific Coastal hazard assessment is to be carried out in accordance with:               <ol style="list-style-type: none"> <li>SC6.5.5 (Coastal hazard assessment report);</li> <li>Guideline: A risk assessment approach to development assessment in coastal hazard areas, DEHP, 2013;</li> <li>AS/NZS ISO 31000: 2009 Risk management– Principles and guidelines;</li> <li>Draft SPP Guideline, state interest—natural hazards, Guidance on coastal hazards; and</li> <li>current engineering best practice.</li> </ol> </li> <li>All investigations, testing and design should be undertaken in accordance with industry practice and the provisions of relevant Australian Standards.</li> </ul>
Flood hazard assessment report	<ul style="list-style-type: none"> <li>Prepared by a Registered Professional Engineer Queensland or equivalent with experience in flood hazard assessment and flood management.</li> <li>Consultation with other entities may also be necessary including Council, State government and other relevant agencies or individuals (e.g. Utility providers).</li> </ul>	<ul style="list-style-type: none"> <li>A site specific Flood hazard assessment report may be requested to provide additional information to Council.</li> <li>A site specific Flood hazard assessment is to be conducted in accordance with:               <ol style="list-style-type: none"> <li>SC6.5.6 (Flood hazard assessment report); and</li> <li>AS/NZS ISO 31000: 2009 Risk management – Principles and guidelines;</li> </ol> </li> <li>All investigations, testing and design should be undertaken in accordance with industry practice and the provisions of relevant Australian Standards.</li> </ul>
Landslide hazard (geotechnical) assessment report	<ul style="list-style-type: none"> <li>Prepared by a Registered Professional Engineer Queensland or equivalent:               <ol style="list-style-type: none"> <li>who holds a degree in civil engineering or</li> </ol> </li> </ul>	<ul style="list-style-type: none"> <li>The site-specific Landslide hazard (geotechnical) assessment report may be requested to provide additional information to Council.</li> </ul>

	<p>engineering geology with current membership of a recognised professional institution and whose primary business (with a minimum of 10 years of experience) is in the field of geotechnical engineering or engineering geology; or</p> <p>b) who has local experience with landslides or demonstrable general experience with landslides and their mitigation and rehabilitation.</p> <ul style="list-style-type: none"> <li>• Consultation with other entities may also be necessary including Council, State government and other relevant agencies or individuals.</li> </ul>	<ul style="list-style-type: none"> <li>• A site specific Landslide hazard (geotechnical) assessment report is to be prepared in accordance with SC6.5.7</li> <li>• A Landslide risk assessment is to be prepared in accordance with the Landslide Risk Management Guidelines (Australian Geomechanics Society 2007, c and d) in Australian Geomechanics, Volume 42, No. 1 March 2007, or any later guideline of the Australian Geomechanics Society as agreed by Council and is to be provided as part of the site specific Landslide hazard (Geotechnical) assessment report.</li> <li>• All investigations, testing and design should be undertaken in accordance with industry practice and the provisions of relevant Australian Standards.</li> </ul>
--	--	--

### SC6.5.3 Coastal hazard assessment report

#### SC6.5.3.1 Purpose of a Coastal hazard assessment report

- (1) A Coastal hazard assessment report is required to:
  - (a) demonstrate that a development will not increase risk to people and property from coastal hazards impact or create an adverse coastal hazard impact including an impact on the ongoing operation of development in coastal hazard areas; and
  - (b) provide information and guidance to support the outcomes required by the Coastal environment overlay code.

#### SC6.5.3.2 Desired outcomes for a Coastal hazard assessment report

- (1) The following minimum outcomes have been identified to guide the consideration of risk to development from a coastal hazard. These outcomes in Table SC 6.5.5.2.1 (Outcomes for a coastal hazard assessment report) are not necessarily exhaustive having regard to a site or development.

**Table SC 6.5.3.2.1 Outcomes for a coastal hazard assessment report**

<b>Outcome 1</b>	Development in an area subject to a coastal hazard protects safety and amenity.
<b>Outcome 2</b>	Buildings and structures are designed to withstand coastal hazards and minimise cost and disruption to the community associated with responding to coastal hazard impacts.
<b>Outcome 3</b>	An acceptable standard of amenity for future users of the premises is achieved.
<b>Outcome 4</b>	Difficult to evacuate uses and vulnerable uses are to be located outside of Medium storm-tide sub-category areas and the High storm-tide sub-category coastal hazard areas.
<b>Outcome 5</b>	Development relying on an evacuation route or supporting infrastructure located elsewhere demonstrates that those elements in themselves are not susceptible to a coastal hazard.
<b>Outcome 6</b>	Any action taken to mitigate the impacts of coastal hazards does not impact adversely on an adjacent premise or the ability of others to implement their future adapt, defend or retreat actions.
<b>Outcome 7</b>	Development in an area subject to coastal hazards protects biodiversity, the integrity of environmental networks and coastal resources.

#### SC6.5.3.3 Undertaking a Coastal hazard assessment report

- (1) The nature and severity of flood actions is to be established for the site and is to inform the appropriate site and use mitigation measures that are development specific.
- (2) The coastal hazard assessment is to address the sources of coastal hazards, specifically including both the impacts of storm tide and longer term salt-water inundation due to tidal flooding.
- (3) The flood actions to be considered in the coastal hazard assessment include the following:
  - (a) the extent of inundation;
  - (b) flow velocities and depths of inundation through the assessment area;

- (c) hydrostatic and hydrodynamic forces on a structure and a building;
- (d) debris impacts;
- (e) proximity to coastal waters and associated wave actions;
- (f) erosion and associated scour;
- (g) distance to land unaffected by flooding; and
- (h) duration of flooding.

#### **SC6.5.3.4 Preparation of a Coastal hazard assessment report**

- (1) The Coastal hazard assessment report is to:
  - (a) include a Coastal risk assessment, as detailed in Table SC 6.5.2.1 (Requirements of natural hazard documentation ) of this planning scheme policy;
  - (b) describe the impacts of coastal hazards on the site;
  - (c) describe all proposed mitigation measures for the site. These mitigation measures are to:
    - (i) address the full extent of exposure to flood action;
    - (ii) address the location, design, siting, construction, and operational procedures for the development;
    - (iii) determine the risk of scour or erosion for the particular coastal hazard area and mitigation methods;
    - (iv) be specific to the full extent, nature and characteristics of the intended use, including affected populations;
    - (v) be contained wholly on the site; and
    - (vi) include existing or committed defence measures in developing a site-specific response.
  - (d) address the outcomes for a Coastal hazard assessment report as detailed in Table SC 6.5.5.2 (Desired outcomes for a Coastal hazard assessment report) detailed in this planning scheme policy;
  - (e) describe any residual risks likely to be experienced on site or created by the development external to the site.

## **SC6.5.4 Flood hazard assessment report**

### **SC6.5.4.1 Purpose of a Flood hazard assessment report**

- (1) A Flood hazard assessment report is required to:
  - (a) quantify the flood hazard for a particular site at the year 2100;
  - (b) ensure appropriate methods are implemented to appropriately mitigate or avoid the risk of flood hazard; and
  - (c) provide information and guidance to support the outcomes required by the Flood hazard overlay code and the Coastal hazard overlay code.

### **SC6.5.4.2 Preparing a Flood hazard assessment report**

- (1) The Flood hazard assessment report is to include the following key elements:
  - (a) assessment of the flood risk and implications up to and in excess of the defined flood event at the year 2100; the flood risk does not stop at the defined flood event so the suitability of a land use must consider the implications of larger floods, particularly in regard to the risk to people. The following should be identified:
    - (i) the potential impacts of flood hazard on the development;
    - (ii) the potential impacts of the development on flood hazard;
    - (iii) the location and height of buildings, particularly habitable floor areas;
    - (iv) the location and design of plant and equipment, including electrical fittings; and
    - (v) impact of increases in rainfall intensity at 2100 in regard to safety and property damage;
    - (vi) in the case of overland flow flooding a severe storm impact assessment being provided in accordance with Queensland Urban Drainage Manual;
    - (vii) as relevant, include accurate hydrological and hydraulic modelling for the waterway network and assessment of existing flooding and flood levels of major water systems, including modelling of the 50%, 10%, 1%, 0.5% and 0.2% AEP flood events and the Probable Maximum Flood (PMF);
    - (viii) address the potential impacts of climate change, including the projected sea level rise of 0.8m; and
    - (ix) the 1% AEP flood event at the year 2100 to inform the DFE;
  - (b) identification of the stakeholders exposed to or affected by the risk of flooding and their compatibility to the risk and how flood risk to people is managed. specifically identifying:
    - (i) number of people likely to be at risk and who may need to be evacuated;
    - (ii) special care uses (the publication Evacuation Planning by Emergency Management Australia (Commonwealth Government 2005) provides a list of special needs groups);
  - (c) identification of public and private premises, social systems and environmental elements at risk of flooding, including consideration of extreme flood events;
  - (d) identification of all critical electrical services, hazardous storages and other high risk elements;

- (e) evacuation routes – identify applicable routes, if relied upon, and flood immunity of those routes, and an assessment of the safety of people moving to those routes;
  - (f) isolation – potential to have evacuation route cut off early in the flood;
  - (g) burden placed on emergency services – while important to allow safe access for emergency services, they cannot be relied on as a solution to egress difficulties and evacuation;
  - (h) special care requirements at evacuation destination – uses focused on vulnerable people such as children or elderly and their special requirements for care and the ability of evacuation centres to provide that care;
  - (i) length of flood recovery and social and economic impacts; that is, the likelihood and consequences of flooding. This evaluation requires a quantitative analysis that uses numerical values, rather than the descriptive scales used in qualitative and semi-quantitative analysis for both consequences and likelihood. The quality of the analysis depends on the accuracy and completeness of the numerical values used
  - (j) flood-resilient design – this may include both using flood-compatible materials and building design aspects such as locating the least flood-tolerant uses at the highest development levels; and
  - (k) definition of flood hazard management strategies is to include:
    - (i) a description and evaluation as to the impact of the proposed mitigation strategies on the existing and likely future use of land and buildings in proximity to the proposed development;
    - (ii) the proposed method of perpetuating the restricted use and required mitigation measures through appropriate forms of legal documentation, notation on titles and methods for conveying the risk management data to future owners and leaseholders; and
    - (iii) the procedure to conduct emergency flood management, evacuation and rescue operations including flood emergency management plans.
- (2) Development which proposes a lowering of flood immunity standards through a risk assessment (usually an industrial use) is to ensure the building materials are constructed of flood-compatible materials.
- (3) A flood hazard assessment report must identify the Flood hazard category in accordance with Table SC6.5.6.2.1 Flood risk, which will be applied in the assessment of the development.

**Table SC 6.5.4.2.1 Flood risk**

<b>Flood Hazard Category</b>	<b>Description</b>	<b>Depth/Velocity Limit</b>	<b>Depth Limit</b>	<b>Velocity Limit</b>
<b>Low</b>	Unsafe for small vehicles.	≤ 0.6 m <sup>2</sup> /s	≤ 0.5 m	≤ 2.0m/s
<b>Medium</b>	Unsafe for vehicles and people	> 0.6 m <sup>2</sup> /s to ≤ 1.0 m <sup>2</sup> /s	≤ 1.2 m to ≤ 2.0 m	≤ 2.0m/s
<b>High</b>	Unsafe for vehicles and people. All building types considered vulnerable to failure.	> 1.1 m <sup>2</sup> /s	> 2.1m	> 2.0m/s

## **SC6.5.5 Landslide hazard (geotechnical) assessment report**

### **SC6.5.5.1 Purpose of a Landslide hazard (geotechnical) assessment report**

- (1) The Landslide hazard (geotechnical) assessment report is required to:
  - (a) quantify the landslide hazard for a particular site;
  - (b) ensure appropriate methods are implemented to appropriately mitigate or avoid the risk of landslide hazard; and
  - (c) provide information and guidance to support the outcomes required by the Landslide hazard overlay code.

### **SC6.5.5.2 Risk assessment criteria**

- (1) For the purposes of completing the risk assessment, tolerable risk criteria apply and are specified by the Australian Geomechanics Society in Table 1 (AGS Suggested Tolerable loss of life individual risk) in the Practice Note Guidelines for Landslide Risk Management 2007, except where societal risk applies as noted below.
- (2) 'Acceptable risk' criteria as described in *Australian Geomechanics Society 2007 Practice note guidelines for landslide risk management 2007* are one order of magnitude lower than 'tolerable risk' as specified in Table 1 (AGS Suggested Tolerable loss of life individual risk) and are to apply to:
  - (a) essential community infrastructure;
  - (b) sensitive uses;
  - (c) assembly uses;
  - (d) difficult to evacuate uses; and
  - (e) hazardous materials.

### **SC6.5.5.3 Preparing a Landslide hazard (geotechnical) assessment report**

- (1) The site-specific Landslide hazard (geotechnical) assessment report is to include a landslide risk assessment, as detailed in Table SC 6.5.2.1 (Requirements of Natural hazard documentation) of this planning scheme policy and demonstrate that development on land susceptible to landslide has had appropriate regard to the geological elements including landslide risk on the site.
- (2) The site specific Landslide hazard (geotechnical) assessment report is to:
  - (a) include recommendations and a conclusion that are supported by the data and all stated assumptions contained in the assessment;
  - (b) be capable of being verified by a peer review;
  - (c) state whether the site is suitable for the development in compliance with the risk assessment criteria in SC6.5.7.2 (Risk assessment criteria) for the loss of life and for property loss; and
  - (d) identify the risk mitigation measures for the site.
- (3) As a guide the following report format and contents description indicates the depth of detail required:

- (a) an introduction including details of the development, such as site location and description including the real property description and the proposed development, reconfiguring a lot or construction details;
- (b) a description of existing conditions, including existing research material:
  - (i) aerial photographs;
  - (ii) geological maps;
  - (iii) geological reports;
  - (iv) site classification;
  - (v) geology (local and regional), including:
    - (A) surface and sub-surface materials; and
    - (B) geomorphology (slopes, ground contours, natural features, terrain analysis, landslide features);
  - (vi) site history, including the location size and type of previous landslips on or affecting the site and hazards outside the site but likely to affect it, such as landslides or rockfalls upslope of the site;
  - (vii) groundwater, including:
    - (A) watertable; and
    - (B) springs and seepage areas in the local area of interest;
  - (viii) surface drainage patterns;
  - (ix) vegetation cover on and around the site; and
  - (x) buildings, other structures, earthworks;
- (c) an assessment of land stability/suitability, including:
  - (i) proposed development components;
  - (ii) a landslide risk assessment for the site indicating the likelihood and consequences of landslides on, above or near the site affecting the development and the calculated risk to life and property having regard to SC6.5.7.2 (Risk assessment criteria) in accordance with *Australian Geomechanics Society 2007 Practice note guidelines for landslide risk management 2007*; and
  - (iii) potential geotechnical effects of the development on land stability;
- (d) an assessment of development impacts, including:
  - (i) site layout;
  - (ii) roadworks, driveways and other pavements;
  - (iii) earthworks (excavation, materials usage);
  - (iv) foundations;
  - (v) surface drainage;
  - (vi) wastewater (treatment and disposal);
  - (vii) detailed existing stability of the site and of geotechnical constraints on buildings or other development work on the site as well as on land above and below the site;
  - (viii) overall effect of development on the stability of the site as well as on land above and below the site; and
  - (ix) overall effect of any site sewage disposal system or rainwater run-off system on slope stability;
- (e) recommendations on appropriate measures required to avoid or minimise risks of instability or other adverse environmental effects, on the site as well as land above or below the site, including:
  - (i) preferred locations for buildings, other structures and driveways;
  - (ii) foundation requirements;
  - (iii) pavement types and design;
  - (iv) construction methods to avoid problem areas;
  - (v) preferred excavation, retention and stabilisation techniques and the suitability of excavated materials for use in on-site earthworks;
  - (vi) surface and sub-surface drainage requirements;
  - (vii) preferred methods of wastewater disposal;

- (viii) storage of hazardous materials;
  - (ix) safety of key evacuation routes;
  - (x) vegetation protection and revegetation requirements; and
  - (xi) design life adopted;
- (f) a Management plan for engineering solutions anticipated to become Council assets, detailing design life, maintenance requirements, maintenance costs and possible alternatives analysis considering long-term stability, risk and life cycle cost;
- (g) a summary and conclusions on the overall suitability of the land for the proposed development; and
- (h) appendices for field and laboratory test results, including the location and level of field investigations such as boreholes and trench pits.

Note – Overall or Global Slope Stability Certification may be assigned where the development has been assessed as Very low risk in accordance with *Australian Geomechanics Journal Vol 42., No.1. March 2007*, and the following has been met:

- (a) Slope has been reduced by cut and fill, with fill being laid under Level 1 supervision in accordance with AS3798;
- (b) All fill is retained by means of appropriately designed retaining walls, certified by an RPEQ engineer competent in geotechnical design;
- (c) Cuts and cut angles to promote long-term stability are determined by a detailed geotechnical investigation and are assessed for stability; and
- (d) Prior to signing of the Plan of subdivision, applicant provides geotechnical certification written by an experienced and qualified geotechnical professional, certifying that the subdivision has been constructed in accordance with the approved plans and the landslide risk level is very low in accordance with *Australian Geomechanics Society 2007 Practice note guidelines for landslide risk management 2007*.

Development within an area assigned an Overall or Global Slope Stability Certification will still require certification by a suitably qualified geotechnical professional to ensure works maintain landslide risk as Low in accordance with *Australian Geomechanics Society 2007 Practice note guidelines for landslide risk management 2007*. Works shall be carried out in accordance with the Overall or Global Slope Stability Certification.

## **SC6.6 Third party advice or comment planning scheme policy**

### **SC6.6.1 Introduction**

#### **SC6.6.1.1 Relationship to the Planning Scheme**

- (1) This planning scheme policy applies to any development application which has been 'properly made' with Council for assessment against the Planning Scheme. Council may require further expert advice or want to seek comments from a special interest person or group on the development application.

#### **SC6.6.1.2 Purpose**

- (1) This planning scheme policy:
  - (a) allows Local government to seek advice or comment, where appropriate, about an application in any circumstances the Local government determines, including, in the Local government's opinion if:
    - (i) the development may conflict with an overlay;
    - (ii) specialised technical advice is required to assess the development; or
    - (iii) the development may affect premises being of special interest to a person.
  - (b) describes the methods which may be used by Council to obtain third party advice or comment on a particular development application prior to the commencement of the Decision Stage.

### **SC6.6.2 Third party consultation**

- (1) The purpose of Consultation is to seek third party advice or comment on any development application prior to the commencement of the Decision Stage. The advice may be sought from any individual, stakeholder or interest group.
- (2) The advice or comment may be sought in any appropriate way, including:
  - (a) public notification in the newspaper; or
  - (b) placing a notice on the premises; or
  - (c) placing a notice on public land; or
  - (d) personal notification or contact; or
  - (e) public meetings; or
  - (f) meeting with a person having a special interest.
- (3) When seeking third party advice or comment, Council will provide appropriate information on the proposal including:
  - (a) a description of the proposal;

- (b) details of where the development application can be inspected;
  - (c) provide a copy of relevant information;
  - (d) details of where comments may be lodged; and
  - (e) the last day upon which Council will accept advice or comment.
- (4) The providing of third party advice or comment for a development application under this planning scheme policy does not provide the consulted party with any Appeal Rights as described by The Act.

## **SC6.7 Growth management planning scheme policy**

### **SC6.7.1 Introduction**

#### **SC6.7.1.1 Relationship to the Planning Scheme**

- (1) This planning scheme policy provides:
  - (a) information the Council may request for a development application; and
  - (b) guidance or advice about satisfying an assessment benchmarks which identifies this planning scheme policy as providing that guidance or advice.

#### **SC6.7.1.2 Purpose**

- (1) The purpose of this planning scheme policy is to provide information, guidance and advice for satisfying the assessment benchmarks for the preparation of a site specific:
  - (a) Development needs assessment report;
  - (b) Economic impact assessment report;
  - (c) Structure plan; and
  - (d) Traffic impact assessment report.

## SC6.7.2 Requirements of growth management documentation

- (1) Growth management documentation is to be prepared in a clear and concise manner, consistent with the elements identified in Table SC 6.7.2.1 (Requirements of growth management documentation) below, as well as any specific requirements identified in the relevant sub-sections of this report.

**Table SC 6.7.2.1 Requirements of growth management documentation**

Documentation	Preparation	Report requirements
Development needs assessment report	<ul style="list-style-type: none"> <li>Prepared by a suitably qualified professional with appropriate technical expertise in economics and economic assessments.</li> <li>Consultation with other entities may also be necessary including Council, State government and other relevant agencies or individuals (e.g. business owners).</li> </ul>	<ul style="list-style-type: none"> <li>A Development needs assessment report may be requested to provide additional information to Council.</li> <li>A Development needs assessment report is to be prepared in accordance with SC6.7.3 (Development needs assessment report)</li> </ul>
Economic impact assessment report	<ul style="list-style-type: none"> <li>Prepared by a suitably qualified professional with appropriate technical expertise in economics and economic assessments.</li> <li>Consultation with other entities may also be necessary including Council, State government and other relevant agencies or individuals (e.g. business owners).</li> </ul>	<ul style="list-style-type: none"> <li>An Economic impact assessment report may be requested to provide additional information to Council.</li> <li>An Economic impact assessment report is to be prepared in accordance with SC6.7.4 (Economic impact assessment report)</li> </ul>
Structure plan	<ul style="list-style-type: none"> <li>Prepared by a suitably qualified professional with appropriate technical expertise in planning and design and the preparation of Structure plans.</li> <li>Consultation with other entities may also be necessary including Council, State government and other relevant agencies or individuals.</li> </ul>	<ul style="list-style-type: none"> <li>A Structure plan may be requested to provide additional information to Council.</li> <li>A Structure plan is to be prepared in accordance with SC6.7.5 (Structure plan)</li> </ul>
Traffic impact assessment report	<ul style="list-style-type: none"> <li>Prepared by a traffic engineer who is a Registered professional Engineer Queensland.</li> <li>Consultation with other entities may also be necessary including Council, State government and other relevant agencies or individuals.</li> </ul>	<ul style="list-style-type: none"> <li>A Traffic impact assessment report may be requested to provide additional information to Council.</li> <li>A Traffic impact assessment report is to be prepared in accordance with:               <ol style="list-style-type: none"> <li>SC6.7.6 (Traffic impact assessment report);</li> <li>Guidelines for Assessment of Road Impacts of Development, Queensland Government, Department of Main Roads; and</li> <li>SC6.8 (WRC development manual).</li> </ol> </li> </ul>

		<ul style="list-style-type: none"><li>• All investigations, testing and design should be undertaken in accordance with industry practice and the provisions of relevant Australian Standards.</li></ul>
--	--	---

### **SC6.7.3 Development needs assessment report**

#### **SC6.7.3.1 Purpose of a Development needs assessment report**

- (1) A Development needs assessment report is required to:
  - (a) justify the need for the development given the current demand and supply of existing land and uses; and
  - (b) ensure the development is economically feasible, with appropriate methods implemented to mitigate or avoid any negative impacts that may result from the development.

#### **SC6.7.3.2 Preparation of a Development needs assessment report**

- (1) A Development needs assessment report is to include at a minimum:
  - (a) a supply analysis of land zoned for the same or similar purpose as that proposed by the development within the broader locality, having regard for:
    - (i) existing supply of developed and undeveloped land zoned for the same or similar purpose as that proposed;
    - (ii) current competition for undeveloped land zoned for the same or similar purpose as that proposed;
    - (iii) the consistency of the location with regard to the function and accessibility of the development, including infrastructure provision; and
    - (iv) whether, if not satisfactorily located, it would jeopardise the provision of facilities in a location better placed to provide a higher level of choice or degree of convenience and accessibility;
  - (b) a demand analysis of land zoned for the same or similar purpose as that proposed by the development within the broader locality, having regard for:
    - (v) the existing population currently serviced by existing development and the socio-economic characteristic of this population;
    - (vi) the population anticipated to be serviced by the proposal over a short, medium and long term planning horizon and the socio-economic characteristic of this population;
    - (vii) the existing and anticipated demand for floor space/dwellings over a short, medium and long term planning horizon; and
    - (viii) establishment as to whether the proposed development would result in an excess of developed land (for that purpose) locally and within the broader context of the area; and whether the proposed development may be premature or inappropriate in this regard;
  - (c) the economic feasibility of the proposed development, having regard for:
    - (ix) the identified existing supply and demand (and future anticipated demand);
    - (x) the capacity/capability/maturity of the market to achieve what is required at a feasible rate and scale;
    - (xi) the development size;
    - (xii) nature of the services proposed to be included within it;
    - (xiii) configuration of the general road network which is likely to provide access to the development;
    - (xiv) location of any physical or psychological barriers to movement;
    - (xv) location of complimentary, competing/similar development;
    - (xvi) expected direct and indirect development employment during construction and operations;
    - (xvii) changing trends in lifestyle choices and social behaviour relating to community needs which may affect the proposal; and

- (xviii) any other benefits or detriments to the local area or the community in general; and
- (d) outline and detail the measures that will be implemented to avoid or mitigate significant impacts identified in the assessment.

## **SC6.7.4 Economic impact assessment report**

### **SC6.7.4.1 Purpose of an Economic impact assessment report**

- (1) An Economic impact assessment report is required to:
  - (a) quantify the economic effects a development may have on surrounding uses; and
  - (b) ensure appropriate methods are implemented to appropriately mitigate or avoid any negative impacts that may be result from the development.

### **SC6.7.4.2 Preparation of an Economic impact assessment report**

- (1) An Economic impact assessment report is to include at a minimum:
  - (a) the extent of existing floor space and approved new floor space in the area likely to be serviced by the proposed facility and in surrounding areas which could be affected by it;
  - (b) the likely trade area of the proposed facility having regard to the developments:
    - (i) size;
    - (ii) nature of the services proposed to be included within it;
    - (iii) configuration of the general road network which is likely to provide access to the facility;
    - (iv) location of any physical or psychological barriers to movement; and
    - (v) location of competing facilities;
  - (c) the nature and adequacy of existing facilities and approved new facilities in the trade area referred to above and the level of convenience provided by such facilities;
  - (d) the population, existing and projected, for the likely future trade area and the socio-economic characteristics of that population;
  - (e) the demand, or likely future demand, for commercial floor space in the area referred to above;
  - (f) whether the establishment of the proposed facilities would result in:
    - (i) an excess of commercial floor space of the type proposed in the area; or
    - (ii) would result in an excess of commercial floor space generally; and
    - (iii) whether the proposal may be premature or inappropriate in this regard;
  - (g) the likely impact of the proposed development together with the additional cumulative effect of any approved new commercial developments within the same area on existing businesses, with such impacts clearly articulated together with the means by which they can be ameliorated;
  - (h) whether the proposed location:
    - (i) is consistent with the function of the facility;
    - (ii) maximises accessibility within its potential trade area; and
    - (iii) maximises the use of public transport and pedestrian and cycle accessibility;

- (i) whether, if not satisfactorily located, it would jeopardise the provision of facilities in a location better placed to provide a higher level of choice or degree of convenience and accessibility;
- (j) the expected direct and indirect development employment during construction and operations;
- (k) changing trends in shopping and other behaviour relating to community needs which may affect the proposal;
- (l) the environment effects and urban design implications of the proposal;
- (m) any other benefits or detriments to the local area or the community in general, including the expected direct and indirect development employment during construction and operations; and
- (n) outline and detail the measures that will be implemented to avoid or mitigate significant impacts identified in the assessment.

## **SC6.7.5 Structure plan**

### **SC6.7.5.1 Purpose of a Structure plan**

- (1) A Structure plan is required to:
  - (a) identify and align with any structure planning undertaken by Council on the premises or surrounding locality;
  - (b) identify the major elements of the locality surrounding a development that may impact on the planning and design of the site, ensuring the integration of the development and the continuation of corridors, networks and linkages with and beyond the development site;
  - (c) identify how constraints (within the various overlays) or competing interests have been addressed and reconciled; and
  - (d) reconcile how the site will fit into the future development of the surrounding area without compromising the effective and efficient development of those lands.

### **SC6.7.5.2 Preparation of a Structure plan**

- (1) The extent of the information contained in a Structure plan will depend upon the issues and their resolution, the context of the development in the surrounding area, integration with any Structure plan, and the number of overlays that impact on the area and the site. The more constrained the site, the greater the level of detail required to justify the development.
- (2) The major components of the development are to be designed with consideration of this broader context. The Structure plan is to be clear about how the proposed development will integrate with the surrounding community, Structure plans and with the existing parks, service and infrastructure networks and the movement system (road network, public transport facilities and pedestrian and cyclist paths) in the area, including as required by the Transport and parking code.
- (3) The scope of a Structure plan is tailored to match the scale and likely impact of the proposed development and depends on the nature and extent of the:
  - (a) issues associated with the site and the immediate locality surrounding the site, such as land uses, availability of infrastructure, topographical features, significant vegetation, movement systems, natural features, historical features and existing character; and
  - (b) proposal, its uses, the sequence of development and external impacts such as stormwater quality and quantity management, traffic generation, public transport availability, infrastructure capacity, wildlife corridor linkages and social impacts.
- (4) In addition to the general requirements of a Structure plan, an industrial structure plan is to also identify:
  - (a) the most appropriate location for different types of industries to minimise land use incompatibilities and conflicts;
  - (b) the integration of the site with any Structure plan surrounding development including any necessary buffering; and

- (c) that any reconfiguring a lot is appropriate for the intended industry for the locality.
- (5) The steps to be followed and information provided when preparing a Structure plan are outlined below.

### **Step 1: Site and context assessment**

Prior to preparing a Structure plan, an assessment of the site and its context is undertaken and a site description of land prepared, supported by a map containing the following features as a minimum the:

- a) relation to any relevant Structure plan;
- b) development layout;
- c) topography – contours and levels;
- d) existing street network and intersections and future connections (identifying minor road connections required to facilitate efficient movement and connectivity of the local road network), and their treatments and public transport routes and their stops;
- e) existing residences and structures (such as pool, tennis court or shed), land uses and approvals on surrounding sites;
- f) location of nearby schools, shopping centres, employment generators and other community facilities;
- g) location of surrounding existing and proposed park network and pedestrian and cyclist paths; and
- h) existing infrastructure.

### **Step 2: Identification of constraints**

Some land has values or constraints that will influence the location, form and density of development. As a minimum, values and constraints as identified in any overlays are mapped and considered in the design of the overall development.

### **Step 3: Analysis of the site characteristics and constraints and allocation of land uses**

Once the site characteristics and constraints have been identified, they are addressed by the Structure plan as recommended by the relevant codes and local plans where applicable. In some cases it may be possible to develop all or part of constrained sites carefully and sensitively. Alternative approaches may be required to accommodate development, for example lower development yields or sensitive residential design to ensure the retention of land with environmental or scenic constraint or other values. For other sites, development will not be possible. In many cases, a Structure plan, a local plan or provisions within codes will articulate whether development is possible, and if so, how it should occur.

The application must demonstrate integration, namely:

- a) compatibility with any Structure plan and surrounding uses (existing and proposed) with the proposed use/s;
- b) that consideration has been given to the potential for the development and coordinated and integrated development of adjoining land uses; and
- c) that the development does not prejudice the development of an adjoining premises by shifting unreasonable costs of infrastructure onto adjoining premises, such as parks, stormwater management facilities, roads and bridges.

On a smaller site, where it is not possible to include the full range of land uses that support a sustainable community, it is particularly important to demonstrate that the parks are well planned (either on the site, or already approved on adjoining land) and an integrated road network can be achieved.

If a site is in the Residential or Emerging community zone, a Structure plan is to demonstrate that the allocation of land uses ensures the following:

- a) land is used primarily for residential purposes and where relevant aligns with any Structure plan;
- b) residential communities are well serviced and enjoy high amenity by providing for a range of complementary business and employment opportunities and community uses and facilities as early as possible. These may include centres, education facilities, parks, health care facilities, youth clubs and emergency services;
- c) residential development has good access to public transport, local parks, education facilities, shops and community facilities. As such, these uses must be accommodated in locations that maximise the service they provide to the community and minimise any associated impacts. These uses must be centrally located or highly accessible to their respective catchments and wherever possible to be co-located in or near centres. Uses that are likely to draw significant levels of non-local traffic into residential streets will not be approved unless there is a significant offsetting of community benefit and traffic impacts can be minimised;
- d) residential development provides appropriate housing choices for all people and allows residents the opportunity to remain within their neighbourhoods during all stages of their life, with a range of housing choices provided throughout the area. However, houses at low density should predominate; and
- e) development does not impinge on the legitimate operation of existing uses and is suitably buffered from incompatible existing uses on the site or on adjacent land.

Industrial development may occur in the Industry investigation zone subject to the identification of environmental performance of the development and the mechanism for the provision of infrastructure in the development.

When allocating industry investigation zoned land for future industrial development, the nature of the industry and the intended industry zone is to align with the separation distances to sensitive zones as detailed in the Reconfiguring a lot code and the assessment benchmarks of the applicable codes.

If a site in the Centre zone or Mixed use zone, a Structure plan is to detail the following:

- a) integration with any Structure plan, the mixture and proportion of uses and how these will contribute to economic vitality and the physical environment;
- b) key site planning and design elements of the development and how these contribute to the overall centre or corridor structure, movement and circulation network and built form character;
- c) building, open space and landscape siting and how these promote and support:
  - i) economic activity and community service delivery;
  - ii) public transport interchange;
  - iii) accessibility and connectivity;
  - iv) safety and security;
  - v) community use and meeting;
  - vi) higher density residential living;
  - vii) the character and identity of the centre or mixed use area; and

- viii) design for climatic comfort, energy efficiency and subtropical outdoor living;
- d) the streetscape and public space interface including public and publicly accessible spaces and linkages, active frontages or significant corner treatments;
- e) development interfaces to the surrounding neighbourhood, adjoining sites and to other buildings or uses within the site to mitigate and manage amenity impacts;
- f) air or noise impacts on the site and how these will be addressed through use, site planning or building design; and
- g) the existing reduced levels and proposed finished levels for all elements.

#### **Step 4: Document the Structure plan**

The structure plan design, including land use allocation, movement network design, and open space and park network provision, is to actively promote achievement of the applicable zone and the intent of any relevant local plan or Structure plan.

The structure plan design is to also enable the development to comply with the requirements of all other relevant codes unless specified otherwise by a local plan or Structure plan.

The structure plan is to contain the degree of detail appropriate to the particular development and its circumstance and at a minimum map and report on the following:

- a) the approximate lot or dwelling yield for each part of the site (density);
- b) the location of each proposed land use, including where applicable, the extent of facilities proposed such as community facilities, centres, employment and education facilities;
- c) how and where broad physical infrastructure is to be provided such as water, sewerage and stormwater;
- d) the general location and size of parks including corridor linkages and networks and identify the park zone precinct and type that aligns with the intended future function of the site;
- e) the existing and proposed pedestrian and cyclist paths;
- f) the existing and proposed road network, including level in the hierarchy;
- g) the existing and proposed public transport routes and stops; and
- h) the proposed staging of development.

When in map form, the information is to be provided at a maximum scale of 1:2,000 and includes a bar scale and north point.

#### **Step 5: Level of consultation required for a structure plan**

The preparation of a structure plan will entail the level of consultation required by the *Planning Act 2016* for impact assessable development. On smaller sites, the consultation required by the *Planning Act 2016* would generally suffice.

However, where the site or the proposal entails complex issues, or involves a large site with multiple precincts and land uses, and/or the structure plan is inadequately detailed to facilitate informed public submissions, Council may require additional material and community consultation as part of a formal Information Request.

## **SC6.7.6 Traffic impact assessment report**

### **SC6.7.6.1 Purpose of a Structure plan**

- (1) A Traffic impact assessment report is required to:
  - (a) quantify the effects a development may have on traffic movement and safety on the site and adjacent transport network (streets and intersections) within the sphere of impact of the development; and
  - (b) ensure appropriate methods are implemented to appropriately mitigate or avoid any negative impacts that may be result from the development.

### **SC6.7.6.2 Preparation of a Traffic impact assessment report**

- (1) A Traffic impact assessment report includes at a minimum the following information for the site and the adjacent transport network (streets and intersections) within the sphere of impact of the development:
  - (a) an assessment of present traffic operations and safety without the development;
  - (b) an assessment of traffic operations and safety for the following scenarios:
    - (i) at completion of the development, and if the development is staged, also at each significant stage prior, including a comparison between current traffic arrangements and proposed traffic arrangements and an outline of the works proposed to offset anticipated traffic impacts;
    - (ii) without the development on a 10 year planning horizon from completion of the development; and
    - (iii) with the proposed and any additional upgrading works proposed in conjunction with the development on a 10 year planning horizon from completion of the project;  
Note—Council should be consulted regarding the expected traffic growth rates for assessing the future scenarios.
  - (c) a statement describing how the development will provide for safe and convenient movement to, from and within the site;
  - (d) a statement describing how the development will facilitate walking, cycling and greater use of public transport in preference to using private motor vehicles for trips to and from the development;
  - (e) a statement describing how public transport services and infrastructure will be improved as a result of the development, particularly where relating to indented bus bays and bus shelters;
  - (f) a statement describing the measures used to ensure maximum accessibility from the site to public transport, including where future public transport services are envisaged;
  - (g) a statement describing the measures used to ensure that through traffic is not introduced into local street systems;
  - (h) an assessment of existing parking supply and demand in the vicinity of the development for both on- and off-street parking, and an assessment of the impact of the development on this parking supply and demand;

- (i) a statement describing the appropriate provision for parking in the development based on land use and the potential for trip-making by public transport, or by walking and cycling;
- (j) a statement describing the appropriate provision for on-site bicycle parking facilities;
- (k) a statement describing whether the proposed means of ingress to or egress from the development are adequate and located appropriately according to the road hierarchy;
- (l) an assessment of the provisions made for the loading, unloading, manoeuvring and parking of service vehicles within the development and on the subject site;
- (m) an assessment of refuse storage area/s and demonstration of safe vehicle access for the removal of refuse;
- (n) an assessment of the proposed routes within the development used by service vehicles associated with the development, and the impacts of heavy vehicle movements on these routes;
- (o) an assessment of the potential for integration of access with adjacent development through sharing of common ingress and egress arrangements;
- (p) an assessment of the impacts on public transport, traffic operations and parking as a result of any temporary works required during construction;
- (q) a record of any comments made by the Department of Transport and Main Roads or any other State planning authority that comply with the rights and powers of these agencies;
- (r) an assessment of the existing and likely future amenity of the surrounding area, and of the potential impacts of the development on that amenity;
- (s) a statement describing all of the assumptions made in the preparation of the report and the design parameters adopted in the technical analysis;
- (t) a statement describing how traffic generation and parking proposed rates (based on gross floor area) are supported by reference to publicly available documents or attaching actual traffic survey data for a similar activity;
- (u) where development incorporates a mix of residential and non-residential uses the assessment may consider the potential cross-utilisation of car parking. A relaxation of up to 30% of the number of non-residential vehicle parking spaces may be appropriate where the assessment demonstrates a genuine cross utilisation exists between proposed uses on a site;
- (v) a statement describing how the layout of the development provides for the safe movement of pedestrians and cyclists within the development and to/from the core of the development and the frontage streets, taking into account the location of public transport and pedestrian facilities;
- (w) an assessment of the operation of any security boom gate or card reader and its impact on vehicle queuing on the frontage roads; and
- (x) an assessment of traffic signals operation based on existing signal phasing, including impact on adjacent intersections.

## **SC6.8 WRC Development manual planning scheme policy**

### **SC6.8.1 Introduction**

#### **SC6.8.1.1 Relationship to the Planning Scheme**

- (1) The planning scheme policy applies to development requiring submission of approval applications, including design details and construction procedures.
- (2) It is the intention of the WRC Development manual to set out procedures and requirements that are consistent with the *Planning Act* 2016 and its supporting legislation, and represent 'best practice' in accordance with accepted current state and national standards for design and construction.
- (3) The WRC Development manual sets out procedures involved in applying for an Operational Works Permit for Works that will ultimately be in the ownership and maintenance responsibility of Council or other services authorities or works which are subject to approval by Council.

#### **SC6.8.1.2 Purpose**

- (1) This planning scheme policy provides:
  - (a) a comprehensive, practical and authoritative guide through the development approval process from inception to completion for Developer's, Consultants, Contractors and Council Officers; and
  - (b) a consistent set of Engineering standards for implementation across the Whitsunday Region.

### **SC6.8.2 Whitsunday Regional Council (WRC) development manual**

- (1) For further detail regarding procedure or specifications, refer to the WRC development manual document.

## **SC6.9 Waste management policy**

### **SC6.9.1 Introduction**

#### **SC6.9.1.3 Relationship to the Planning Scheme**

- (1) This Planning Scheme policy provides:
  - (a) information the Council may request for a development application; and
  - (b) guidance or advice about satisfying assessment benchmarks which identifies this Planning Scheme policy as providing that guidance or advice.

#### **SC6.9.1.4 Purpose**

- (1) The purpose of this Planning Scheme policy is to provide information guidance and advice for satisfying the assessment benchmarks for the preparation of a site-specific Waste management plan for residential and mixed-use developments.
- (2) This guideline provides guidance to Developers, Architects, Waste Consultants and Town Planners when designing subdivisions, multi-unit and mixed-use developments.

#### **SC6.9.1.5 Preparation of a Waste management plan**

- (1) Waste management must be considered at the design stage of a development. This will ensure sufficient waste capacity to store waste and recycling prior to collections. Sufficient clearance and access for waste collection has been considered and potential health, safety and environment risks are minimised.
- (2) A Waste management plan includes at a minimum the following design principles:

##### **Residential subdivisions**

It is essential that residential subdivisions be designed to be serviced by Council's standard waste service upon occupancy. Providing functional subdivision layouts is essential for safe and adequate service of these developments. The following will be considered in the assessment of development applications for residential subdivisions:

- (a) site planning, lot layout and road design responsive to Council's servicing requirements and provision of safe and adequate bin presentation areas; and
- (b) site planning of the development ensures residential and other user's amenity and safety at all stages of the waste management process.

The standard waste service for residential dwelling unit is a weekly service for waste and fortnightly for recycling, collected from the verge. The design of subdivisions with over four (4) lots may need to incorporate on-site collection where adequate verge space is not available to accommodate bin presentation or where bulk bin services are provided as an alternative to 240L mobile garbage bins.

### **Multi-unit developments**

It is essential that the design of all residential multi-unit developments provides a waste management system that is responsive to the development's needs and is able to be integrated with Council's standard waste management service.

To ensure that multi-unit development can access the Council's waste service in an efficient and effective manner, the following will be considered in the assessment of Development Applications:

- (a) Site planning of the development accommodates on-site waste collection and allows the waste collection vehicle to enter and exit in a forward direction, manoeuvre within the site and access the nominated collection point;
- (b) Waste management system selection ensures safe and convenient use for residents; and
- (c) Adequate waste storage area(s) are provided within the development site to store the required number of waste, recycling, or bulk bin services.

The standard waste service for multi-unit development is an on-site collection service where a nominated bin collection point and loading area is provided. The design of the proposed multi-unit development will need to consider how the waste management systems will be integrated with Council's existing waste collection service.

### **Mixed use developments**

It is essential that the design of all mixed-use development provides a waste management system for the residential component of the development that can be integrated with Council's standard waste management service. Separation of commercial and residential waste storage areas must be maintained.

#### **SC6.9.1.6 Waste management plan**

- (1) A Waste management plan which meets the requirements of these guidelines is to be submitted for the following types of developments:
  - (a) residential subdivisions with 4 or more lots;
  - (b) multi-unit (including multiple dwellings, short term accommodation, rooming accommodation, relocatable home park) residential properties; and
  - (c) developments with multiple uses onsite.

- (2) The Waste management plan requires details on the following items:

#### **(a) Summary of development**

The summary of the development must contain the following information:

- i. location of the development;
- ii. number of storeys;
- iii. number of dwellings units by size (one, two or three bedrooms);

- iv. size of each commercial unit; and
- v. details of the intended use of the development.

**(b) Anticipated waste generation**

Details of the anticipated waste generation for refuse, recycling and other wastes must be calculated using the figures in **Section (r) – Waste generation rates**.

**(c) Receptacle size and quantity**

Details of the size and quantity of the receptacles to be used must be provided. **Section (q) – Receptacle dimensions** contains details of the common size receptacles. Other size receptacles may be used, subject to approval by Council's Waste Services Department. Details of these receptacles must be provided with the Waste management plan.

**(d) Bin storage area**

Design details of the bin storage area must be included in the Waste management plan covering the requirements outlined in **Section (p) – Bin store size**. This includes:

- i. how waste is transported from the source to the bin storage area;
- ii. bin storage area size;
- iii. bin storage area layout;
- iv. wash-down area;
- v. ventilation;
- vi. vermin prevention;
- vii. noise reduction; and
- viii. stormwater ingress prevention.

**(e) Waste system**

Details of any waste systems must be provided including chutes, compactors, and any other waste management equipment or devices to be used.

**(f) Collection method**

The Waste management plan must provide details on proposed collection method to be used in servicing the development. This will include information about the following subjects:

- i. movement of collection vehicle;
- ii. collection location; and
- iii. transfer of waste to the collection vehicle.

Upon the completion and occupation of the development the Waste management plan will provide the framework for the management and collection of waste and recycling.

**(g) Waste collection - Council services**

Council provides the following services to all rateable (residential) properties.

- i. Mobile Garbage Bin (MGB) services consisting of:
  - (A) 1x 240L MGB for waste and 1x 240L MGB for recycling (kerbside); and
  - (B) 1100L and 660L MGBs for waste and recycling (for on-site collection in multi-unit dwellings by arrangement).
- ii. Council's collection services operate Monday to Friday for residential properties; and
- iii. Council's collection contractor operates the following collection vehicles:
  - (A) Side loaders (29m<sup>3</sup> compactor) – waste collections;
  - (B) Side loaders (29m<sup>3</sup> compactor) – recycling collections; and
  - (C) Rear loaders (28m<sup>3</sup> compactor) – waste and recycling collections.

Note - Council does not provide commercial waste collection services.

**(h) Collection frequency**

Council's standard residential service comprises a weekly collection of waste and fortnightly collection of recycling. Multiple weekly services may be provided for multi-unit residential developments by negotiation with Council's Waste Services Department.

Note – Multiple weekly services are subject to agreement with Council and may not always be possible. Where not possible, Council may encourage premises to enter into a commercial agreement with a local service provider. A minimum service charge will still apply in accordance with Council's revenue statement.

**(i) Collection at the verge**

For collection of MGBs at the verge the following conditions shall be met:

- i. a flat area is required of sufficient size to accommodate all the MGBs to be serviced on that day;
- ii. the MGBs are to be placed in single file with no less than 100mm between each MGB. The flat area can either be paved or grass;
- iii. the MGBs placed at the verge shall not obstruct pedestrian traffic or vehicles using the adjacent street and be clear of street signs, trees, seats, litter bins or other permanent fixtures on the verge;
- iv. consideration shall be given to ensure there is no impediment to sight distances to nearby cross-overs and intersections;

- v. the bin collection area shall not be adjacent to street parking bays;
- vi. the MGB shall be placed on the verge no more than 1.5m from the kerb with the lid opening to the road. All bins for collection shall be placed on the verge prior to 6:00 am on the collection day; and
- vii. the movement of MGBs from the complex to the collection point shall not occur on the vehicular access ways.

Note - Overfull bins with lids not closed, 240L MGBs that weigh in excess of 70kg and waste placed outside the MGBs will not be collected.

**(j) Collection within the premises**

MGBs at multi-unit and mixed-use developments may be serviced by Council's contractor from within the bin store or from a location within the premises. If within the premises, a signed indemnity will need to be provided to permit Council's contractor to enter private property.

Where receptacles are presented for service outside of the bin store:

*Bin manoeuvrability*

- i. the surfaces which are traversed must be designed to allow easy transportation of the MGBs and be finished in a way which reduces the noise caused by the MGBs as they are manoeuvred;
- ii. the distance between the bin store and the presentation area is no greater than 10m;
- iii. gradients on the path used to transfer the MGBs from the bin store to the collection point must not exceed 1 in 14 for two wheeled MGBs and 1 in 20 for four wheeled MGBs; and
- iv. the area between the bin store and the collection point shall be a flat smooth surface with no kerbs or steps.

*Bin access*

- i. the minimum pavement width for access to bin stores shall be 4m and the gradient of the access ramp shall be no more than 1 in 8; and
- ii. where bin rooms are secured, a compatible key system is necessary to enable access by collection truck drivers. Details of the proposed locking system are to be included in the Waste management plan for approval by Council's Waste Services Department. All costs associated with the locking system are the responsibility of the developer, property owner/s and/or the strata managers.

*Bin collection*

- i. where on-site collections occur, roadways and infrastructure traversed by the collection vehicle must be constructed to accommodate a heavy truck of 25 tonne gross vehicle mass;
- ii. sufficient overhead clearance is required for access to bin stores that are located in basements or under crofts. This includes clearance to

all structural beams, suspended pipe work, suspended services and the like;

- iii. the basement area shall be free of columns, kerbs and other permanent structures that would inhibit the manoeuvrability of the collection truck;
- iv. sweep paths for the proposed collection vehicles shall be clearly shown on the plans of the proposed development and included in the Waste management plan; and
- v. where private collections are employed the collections must comply with all local, state and federal laws and regulations.

The waste collection vehicle must be able to enter and exit the development in a forward direction, with limited reversing (maximum 3-point turn), parking in a designated location within the property boundaries. This could be facilitated by the inclusion of a turntable.

Please see vehicle dimensions for required adequate vehicle clearance. Where alternative access is proposed, the design is to take into consideration the safety of pedestrian traffic, other vehicles using the area and traffic density on the servicing street.

**(k) Waste chutes**

In high rise developments waste chutes are often proposed to convey waste and recycling from the lobby areas to the bin store. With regard to the lobby area the designer shall consider space restraints, chute design, mechanisms for the separation of waste from recycling and the management of bulky items such as cardboard in the lobby area.

At bin store level consideration shall be given to the safety aspects of the chute operation, rotation of the MGBs beneath the chute, ventilation and mechanical breakdown of the chute system.

Sufficient space shall be provided in the bin store for the manoeuvring of MGBs from beneath the waste and recycling chutes.

**(l) Compaction**

Compaction of garbage can be used where there are constraints on space. Typically the garbage is compacted directly in the MGB using downward force. Garbage compaction shall be restricted to no more than 50% (2:1) of the original garbage volume. Compaction shall not be used for recycling.

**(m) Bin store**

All multi-use developments, which include multiple dwellings, are to provide a dedicated area for the storage of MGBs. The bin store must be of sufficient size to house all the requisite MGBs, include room for manoeuvring the MGBs and include a bin washing area.

**(n) Design requirements**

The bin store will have the following as a minimum:

- i. 75mm thick concrete slab floor with fall to a floor waste trap connected to a sewer;

- ii. a tap with hose to facilitate bin washout and bin store cleaning;
- iii. walls will be constructed of brick, concrete or similar with the inside walls sealed and painted in a light colour to facilitate washout;
- iv. fully enclosed with a wall of 1.8m minimum height;
- v. doors to be solid in nature and lockable with a minimum clear width of 1,200mm, fitted with an efficient self-closing device and a method of holding the doors open when required;
- vi. adequate ventilation to be provided;
- vii. artificial internal and external lighting with movement sensor or mechanical switch controlled;
- viii. all applicable signage;
- ix. MGBs must not be visible from the property boundary except when presented for collection;
- x. the bin storage area shall be undercover to prevent stormwater from entering the sewer;
- xi. where located within a building, the bin store shall be ventilated in accordance with Australian Standard 1668.2: The Use of Ventilation and Air Conditioning in Buildings (as amended);
- xii. where mechanical ventilation is used, the outlet for vented air must be in a location which will not adversely impact residents;
- xiii. sufficient space must be provided to allow the easy passage of MGBs in and out of the bin storage area; and
- xiv. separate bin storage areas are required for residential and commercial waste storage.

**(o) Bin store signage**

An information sheet shall be affixed at the entry to the bin store containing the following information to facilitate safe and efficient waste management at the proposed development. The information sheet will include:

- i. caretaker contact details for any waste related issues;
- ii. bin collection days and times;
- iii. waste types appropriate for each bin type;
- iv. the information sheet will be regularly updated by the caretaker;
- v. any changes or amendments to the waste services shall be passed on to the residents and tenants;
- vi. where waste chutes are used the same sign shall be affixed to the wall in each lobby adjacent to the waste chutes; and
- vii. a sign stating “NO STANDING” fixed to the door of the bin store.

**(p) Bin store size**

The size of the bin store shall be determined using the following criteria:

- i. double the footprint of each MGB shall be used per MGB for MGB storage; and
- ii. three times the footprint of the largest MGB for the wash bay.

The area to be allowed per MGB is shown in **Table SC 6.9.1.1**.

**Table SC 6.9.1.1: Allocation of area per MGB**

MGB Type	Width	Depth	Area of MGB	Allowance per MGB	Allowance for Wash Bay
240 L	0.585 m	0.73 m	0.43 m <sup>2</sup>	1.0 m <sup>2</sup>	2.0 m <sup>2</sup>
660 L	1.26 m	0.78 m	0.98 m <sup>2</sup>	2.0 m <sup>2</sup>	3.0 m <sup>2</sup>
1100 L	1.24 m	1.07 m	1.33 m <sup>2</sup>	3.0 m <sup>2</sup>	4.0 m <sup>2</sup>

**(q) Receptacle dimensions**

- i. 240L MGB - Typical 240L MGB's used by Council are shown in **Figure 1**.

**Figure 1: Details of 240L MGB**

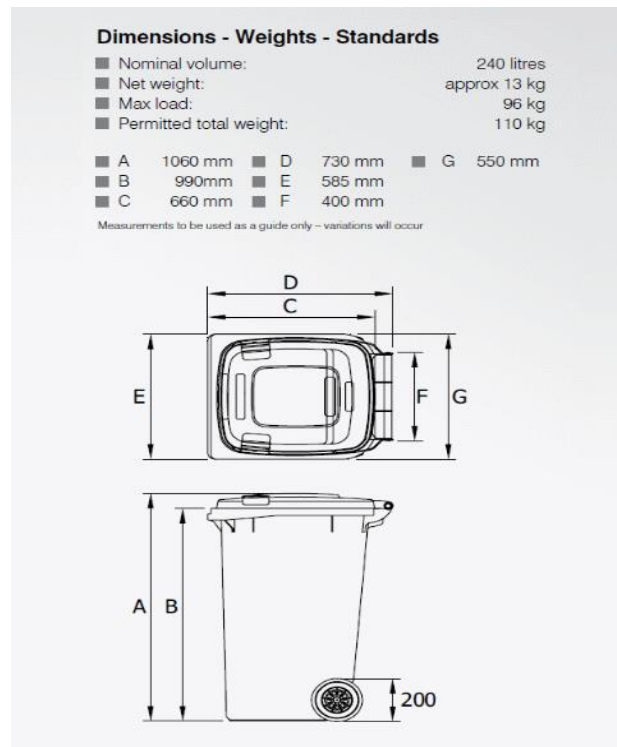
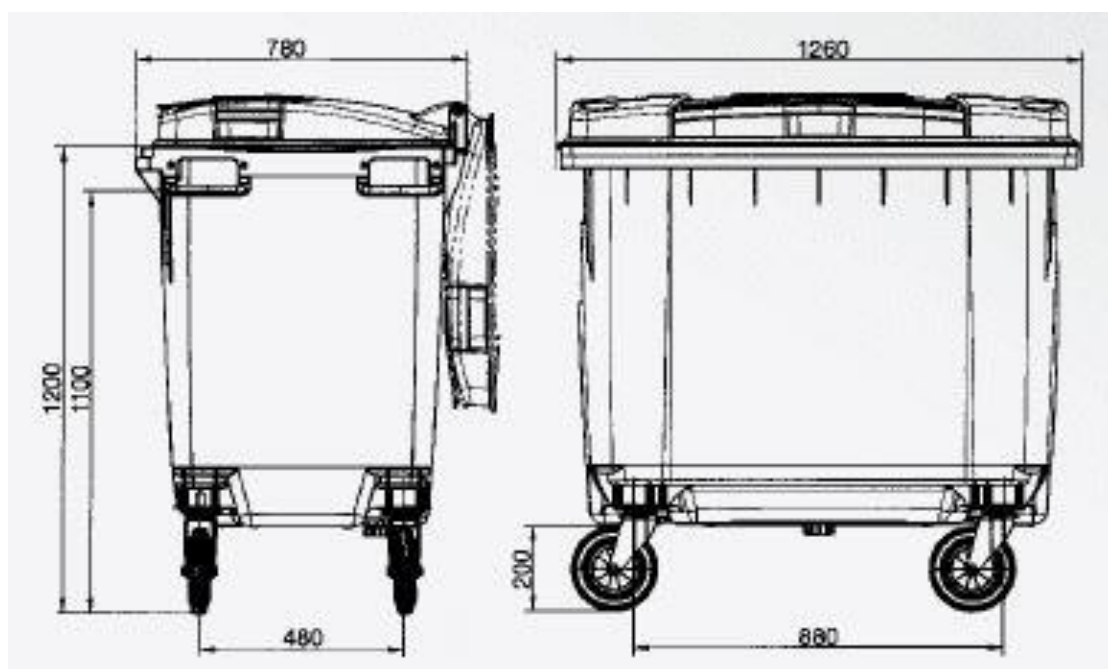

**Figure 2: 240L MGB colours**



- ii. 660L MGB - Typical 660L MGB used by Council are shown in **Figure 3**.

**Figure 3: 660L MGB dimensions**

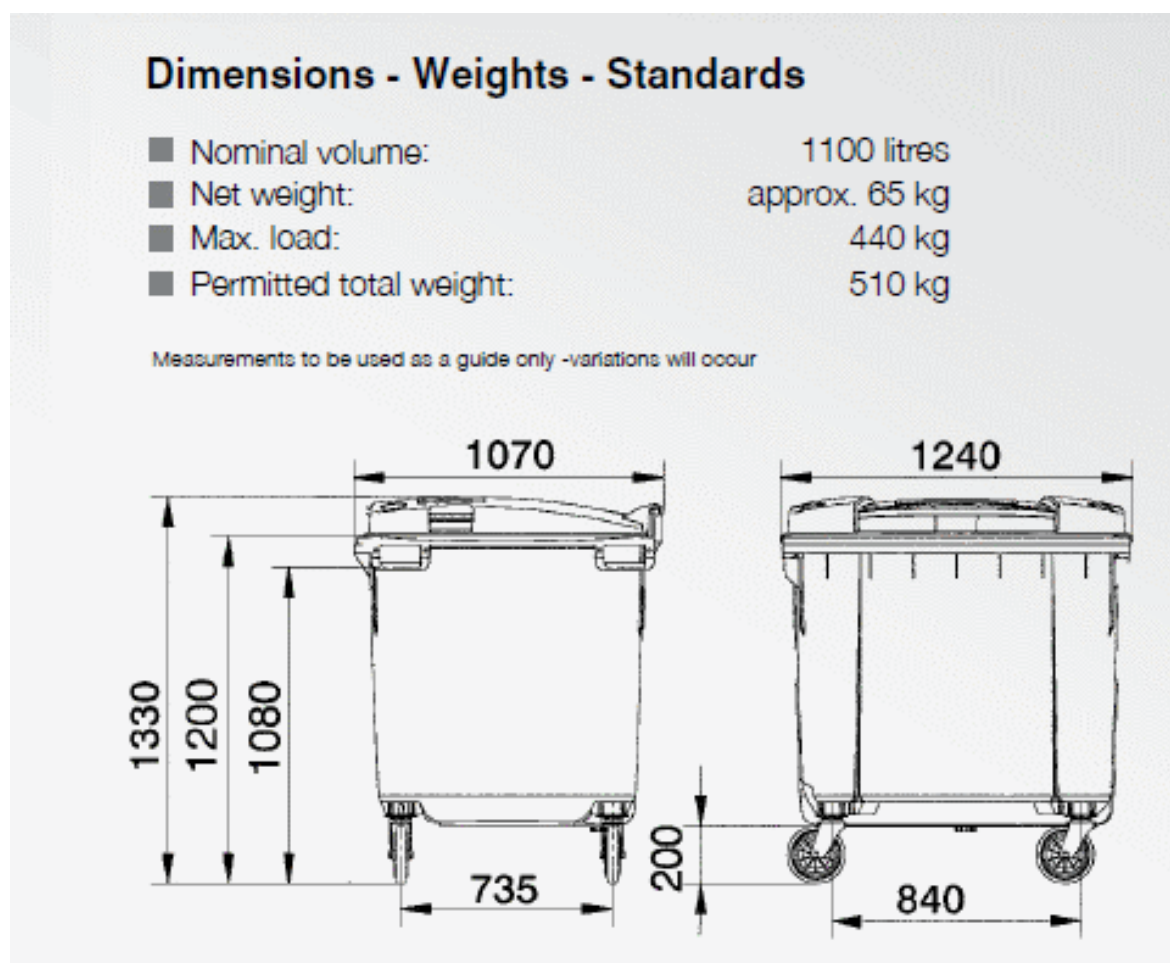

**Figure 4: 660L and 1100L MGB Colours**



- iii. 1100L MGB - Typical 1100L MGB used by Council are shown in **Figure 5**.

**Figure 5: 1100L MGB dimensions**



**(r) Waste generation rates**

- i. developments are to be designed to incorporate waste and recycling storage in accordance with the waste and recycling predicted weekly generation rates shown in **Table SC 6.9.1.2** and **Table SC6.9.1.3**.

**Table SC 6.9.1.2: Residential waste and recycling generation rates**

Type of Premises	Waste (Litres per week)	Recycling (Litres per week)
Serviced apartment	35	35
1 bedroom apartment	80	40
2 bedroom apartment	100	60
3 bedroom apartment	120	60
Individual dwelling	240	120

**Table SC 6.9.1.3: Commercial waste and recycling generation rates**

Type of Premises	Waste Litres/100m <sup>2</sup> floor area/day	Recycling
Take Away Food Outlet / Corner Store / Convenience Store / Lunch Bar	150	150
Café	300	130
Restaurant	660	130
Shops with less than 100 m <sup>2</sup> floor space	50	25
Shops with more than 100 m <sup>2</sup> floor space	50	50
Showrooms	40	10
Taverns and Bars	50	50
Hotel and motel restaurants (dining area)	660	130
Offices	10	10
Hotel and motel accommodation	5 L/bed/day	1 L/bed/day

- ii. where the waste or recycling requirements outlined in **Table SC6.9.1.2** or **Table SC6.9.1.3** above result in a partial bin requirement, this is to be rounded up to the next bin number; and
- iii. where waste chutes are used an additional MGB per chute shall be provided to ensure that there will be MGBs under the chutes in the bin store during times of waste and recycling collection.

**(s) Sweep Paths**

- i. Figure 6 shows the sweep radius of a typical 25 tonne rear load waste collection truck.

**Figure 6: Sweep radius of a 25 tonne rear load truck**

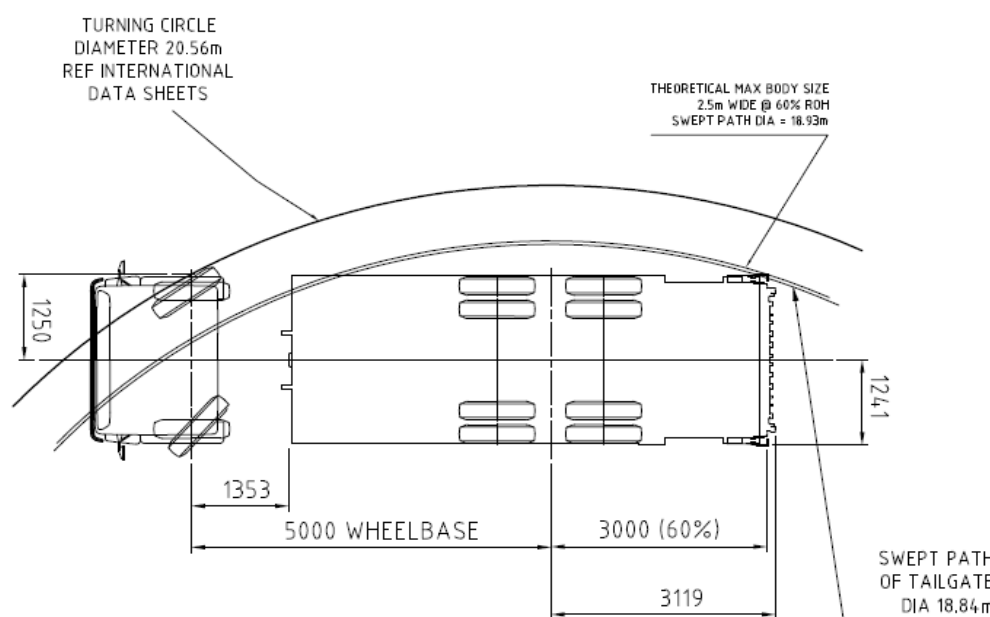

**(t) Assignment of Duties**

The Waste management plan shall clearly convey the responsibilities and duties of Council, strata manager, caretaker, residents and commercial tenants, being:

- i. strata manager:
  - (A) the strata manager shall be required to ensure that the management of waste and recycling at the facility complies with the requirements of the *Environmental Protection Act 1994* and *Public Health Act 2005*, and an appropriately qualified and experienced caretaker is appointed to manage the waste and recycling activities at the complex. the engagement of a caretaker will form part of the strata management agreement for the property, endorsed by all building owners. provision for the payment of the caretaker will be included in the annual strata fees;
- ii. caretaker - the caretaker shall:
  - (A) inspect the waste chutes on each floor of the complex (if used) on a daily basis to ensure that there is no accumulation of waste in the lobby areas, that signage is visible, lobby areas are clean and that the waste chutes are functioning correctly;
  - (B) ensure that the doors on the waste chutes (if used) at the bin store are functioning correctly and that there is no blockages in the waste chutes;
  - (C) change the MGBs at the base of the waste chutes (if used) in the bin store as the MGBs become full;
  - (D) compact waste in the MGBs (if compaction is used) to increase bin capacity;
  - (E) clean and maintain the MGBs and bin store;

- (F) washing and deodorising MGBs as required; and
  - (G) keep up to date with waste collection issues, such as public holiday collection schedules, local service disruptions or changes in collection days;
- iii. commercial tenants - the commercial tenants will be responsible to undertake the following:
- (A) practice correct waste separation of waste and recycling;
  - (B) deposit recyclables loose in their respective recycling MGB; and
  - (C) coordinate with the caretaker in regards to waste management practices and report any issues; and
- iv. residents - the residents will be responsible to undertake the following:
- (A) practice correct waste separation of waste and recycling;
  - (B) deposit recyclables loose in the recycling chute (not bagged); and
  - (C) deposit recyclables loose in their respective recycling MGB.